

Kamasa-TOOLS®

Engine
timing tools

Opel | Vauxhall

K 10533

www.kamasatools.com

Pack Layout

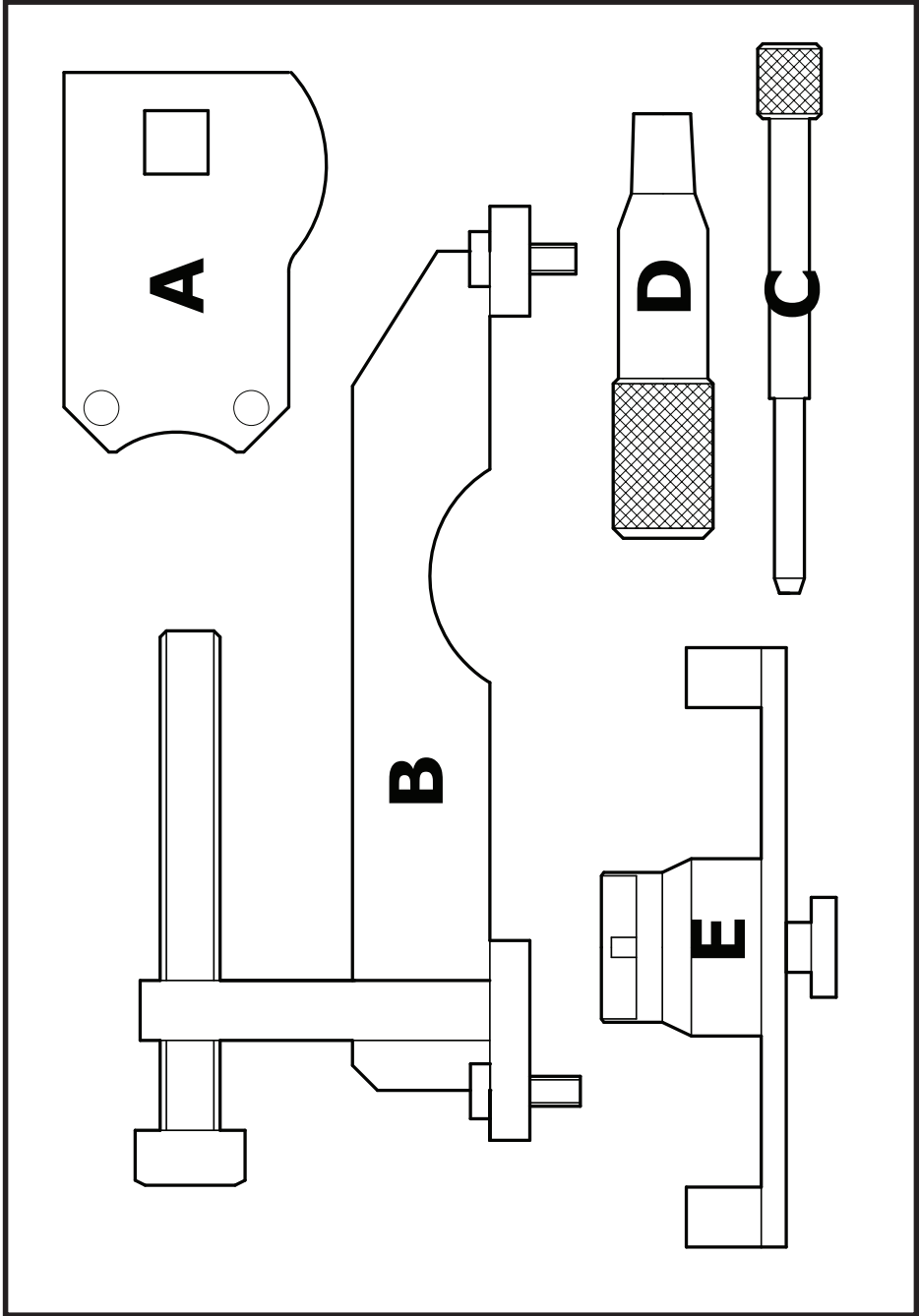

Component identity

Part No.	OEM Ref	Description
A 23164-05	KM-933 83 95 394	Timing Adjustment Wrench
B 23164-06	KM-933 83 95 394	Timing Adjustment Bracket Assembly
C 23164-07	KM-927 83 95 337	Injection Pump Timing Pin
D 23164-08	KM-929 83 95 352	Crankshaft TDC Setting Pin
E 23164-09	KM-932 83 95 386	Camshaft Setting Plate

Applications

Manufacturer	Model	Type	Engine Code	Year
Vauxhall/Opel	Astra-G	2.0 DTi D	X20DTL	1998-02
			Y20DTH	1999-05
			Y20DTL	2000-05
			Y22DTR	2000-06
	Frontera-B	2.2 DTi D	X22DTH	1998-01
			Y22DTH	2000-04
	Omega-B	2.0 DTi D	X20DTH	1998-00
		2.2 DTi D	Y22DTH	2000-03
	Signum	2.0 DTi D	Y20DTH	2003-05
		2.2 DTi D	Y22DTR	2003-05
	Sintra	2.2 Turbo D	X22DTH	1998-99
	Vectra-B	2.0 DTi D	X20DTH	1997-00
			X20DTL	2000-00
			Y20DTH	2000-02
	Vectra-B	2.2 DTi D	Y22DTR	2000-02
	Vectra-C	2.0 DTi D	Y20DTH	2002-05
		DTi D	Y22DTR	2002-05
	Zafira-A	2.0 DTi D	X20DTL	1999-00
		DTi D	Y20DTH	2003-05
	Zafira-A	2.2 DTi D	Y22DTR	2002-05
Saab	9-3	2.2 DTi D	D223L	1998-06

Engine Timing Tools

This set of timing tools enables the correct timing position to be made when servicing Vauxhall/Opel Ecotec 2.0 engines fitted to Vectra-B, Sintra, Zafira, Frontera-B models. Also suitable for use on Saab 9-3 with 2.2D Turbo engine.

Component Application

The correct engine timing position is achieved when the first cylinder is at TDC and each of the timing tools can be correctly fitted.

1. The camshaft is positioned horizontally with the location hole at the top. Use the camshaft setting tool (E) to align the camshaft (see Fig.1)

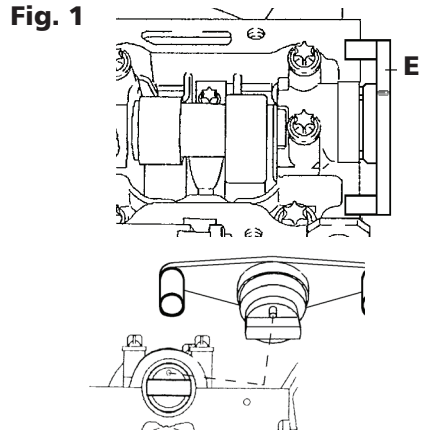

2. The Injection Pump Setting Pin (C) aligns to a timing mark on the sprocket and is fitted through a recess in the injection pump flange and into the retaining hole. (see Fig.2)

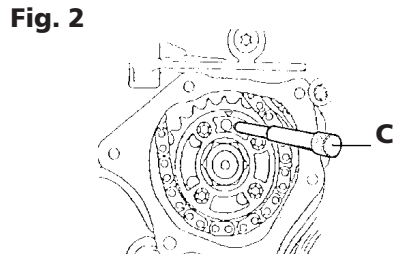

3. The crankshaft locking pin (D) is used to set the crankshaft at TDC position. This tool is fitted through the crankshaft pulse pick-up opening in the engine block and locates into a slot in the crankshaft. (see Fig.3)

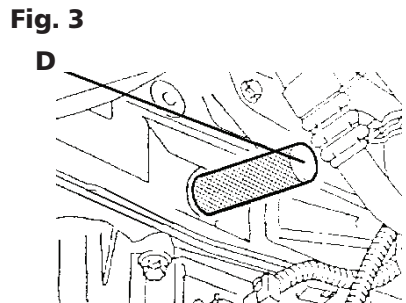

4. Fuel Pump Sprocket Timing Tool (A+B) enables the correct timing position through action to the simplex chain and camshaft sprocket. First attach the special wrench vertically to the sprocket, then attach the bracket assembly to the cylinder head. Using a $\frac{1}{2}$ " Sq. Dr. wrench to apply light pressure to turn the camshaft in an anti-clockwise (contra-engine rotation). The screw is the turned to contact the special wrench and retain this position. (see Fig.4)

Fig. 4

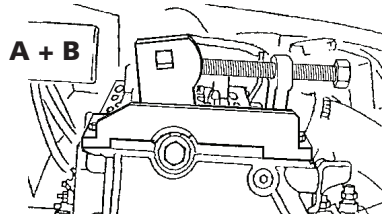

5. At this stage the Pump Locking Pin (C) should be free to be removed and re-fitted. If this pin is tight, adjust the screw until the pin is easy to move. The camshaft sprocket bolt can now be tightened and refit the simplex chain tensioner.

Safety Precautions

- If the engine has been identified as an Interference engine, damage to the engine will occur if the timing belt has been damaged. A compression check of all the cylinders should be taken before the cylinder head (s) are removed.
 - Do not turn crankshaft or camshaft when the timing belt has been removed
 - To make turning the engine easier, remove the spark plugs
 - Observe all tightening torques
 - Do not turn the engine using the camshaft or any other sprocket
 - Disconnect the battery earth lead (Check Radio code is available)
 - Do not use cleaning fluids on belts, sprockets or rollers
 - Some toothed timing belts are not interchangeable. Check the replacement belt has the correct tooth profile
 - Always mark the belt with the direction of running before removal
 - Do not lever or force the belt onto its sprockets
 - Check the ignition timing after the belt has been replaced.
 - Do not use timing pins to lock the engine when slackening or tightening the crankshaft pulley bolts
 - **ALWAYS REFER TO A REPUTABLE MANUFACTURERS WORKSHOP MANUAL**
- Warning Incorrect or out of phase engine timing can result in damage to the valves. It is always recommended to turn the engine slowly, by hand, and to re-check the camshaft and crankshaft timing positions.**



www.kamasatools.com