

***Kamasa-TOOLS***®

Engine  
timing tools

Volkswagen  
Audi Group  
1.4 | 1.6 | 2.0 |  
2.4 | 3.2 FSi/TFSi

K 10535

[www.kamasatools.com](http://www.kamasatools.com)

## Plan Layout

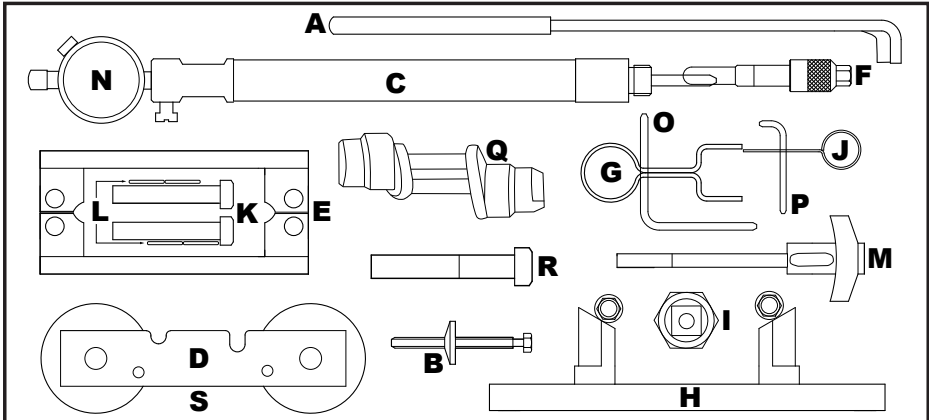

Ref	Oem Ref.	Description
A MM 23044 04Z	T10020	Tension Wrench
B MM 23161 93	T10092	Tensioner Bolt
C MM 23107 B	T10170	5mm TDC
D MM 23162 41	T10171	Camshaft Alignment Tool
E MM 23162 61B	T40070	Camshaft Alignment Tool (2)
F MM 23162 62	T40069	TDC Alignment Pin
G MM 23162 63	T40071	Clip
H MM 23161 91	T10252	Camshaft Setting Tool
I E10516	T40058	Pulley Bolt
J MM 23161 06A	T20046/T40011	Tensioner Locking Pin 1.4mm BZP & Clear Passivate
K DIN 931-1 - M8 x 50		Hex-head Bolt (4)
L AS 1237 - 8		Flat Metal Washers (4)
M MM 23161 92	3366	Chain Tensioner Retainer
N MM 23072 A	VAS6079	DTI -Ord.Style C/W Test Cert.
O MM 23161 96Z	T10060A	Tensioner Pin
P E10517	T10115	Locking Pin
Q E10436	T10414	Camshaft Locking Tool (2)
R MM 23191 02X	T10340	Locking Pin
S MM 23191 01X	T10341	Guide (2)

# Applications

Description: Designed for the full range of FSi/TFSi petrol engines found in the Volkswagen Audi group ranges.

N.B Due to the number of engines covered by this kit it is not possible to give complete instructions for use. The information given below is for reference only.

The Tool Connection recommends the use of Manufacturer data or Autodata.

The Tool Connection cannot be held responsible for damage to engine or personnel whilst using this tool kit.

Applications: Volkswagen Audi Group 1.4 | 1.6 | 2.0 | 2.4 | 3.2 FSi/TFSi engines

Always refer to Vehicle manufacturers data

# Instructions

## Component Descriptions

### Component A

Tensioner Wrench, 2.0lt FSi petrol engines  
Used when replacing the timing belt to back off and set the tensioner. See Fig. 1.

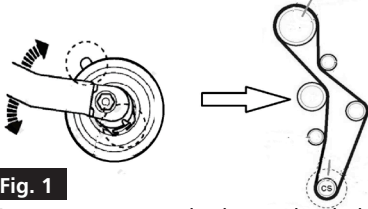

**Fig. 1**

Component A can also be used to help align the inlet camshaft when fitting component H. See Fig. 2.

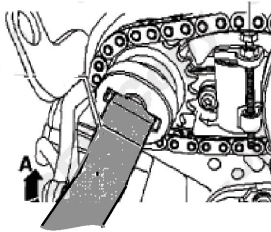
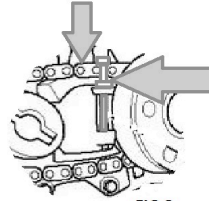

**Fig. 2**

### Components B | J | M

Components B and J are used to set the camshaft transfer chain tensioner in the cylinder head.

There are J types of tensioner used, Use component B as shown in Fig. 3. or component J as shown in Fig. 4. use component M where tensioner is automatic.



**Fig. 3**

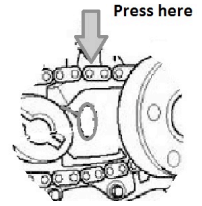

**Fig. 4**

### Component H

Twin camshaft alignment tool for 2.0lt FSi/ TFSi engines is used to lock the camshafts on the 2.0lt FSi and TFSi engines when the transfer chain is to be removed.

Fit component H as shown in Fig. 5. so that the

2 pegs of the component align with the camshaft grooves. Always bolt component H to the cylinder head to ensure alignment.

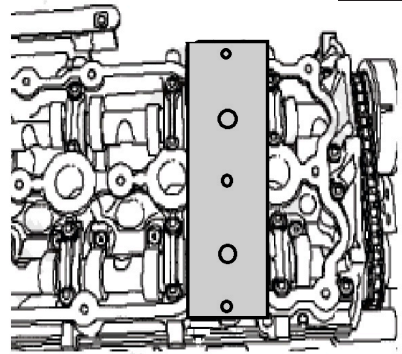

**Fig. 5**

### Components C I N

Components C and N are used to find TDC on number one cylinder as shown in Fig. 6.

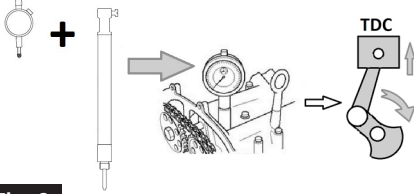

Fig. 6

### Component D

Twin Camshaft timing plate – used to align the camshafts on the 1.4 and 1.6 engines. See Fig. 7.

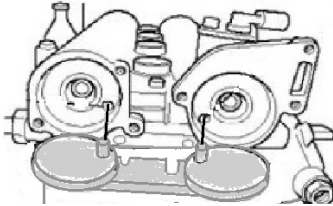

Fig. 7

### Components E I K I L

Components E I K I L - Cam locking bridges for 2.4/3.2 V engines. See Fig. 8.

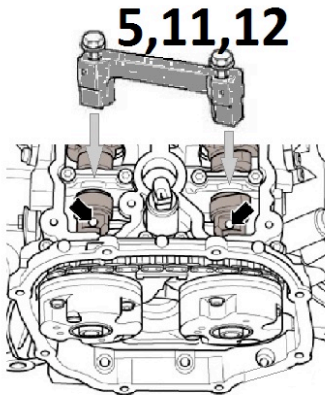

Fig. 8

**Component F** - Crankshaft locking pin for 2.4/3.2 V engines. See Fig. 9.

Remove the blanking plug from the engine block to fit the component F.

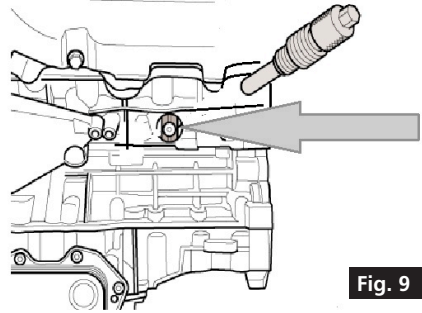

Fig. 9

**Component G** - Chain Tensioner Locking pin – use to lock and hold the chain tensioner on the 2.4/3.2 V engines in its retracted position. See Fig. 10.

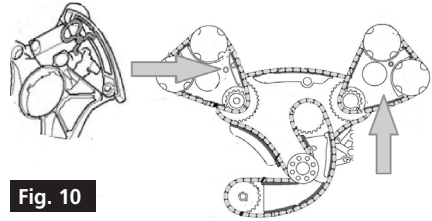

Fig. 10

**Component I** - Crankshaft turning tool. See Fig. 11.

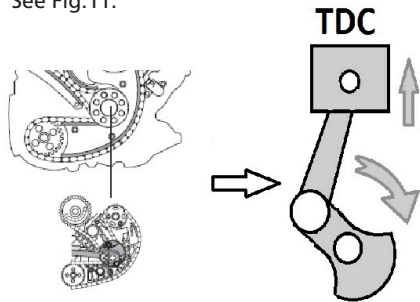
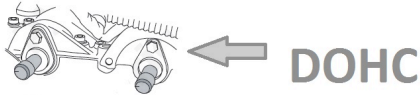
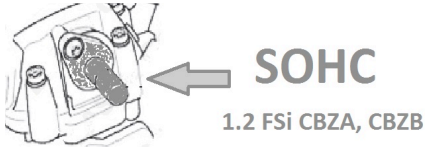

Fig. 11

**Component O | P** – Tensioner locking pins for timing Belt and Auxiliary drive belt tensioner. Use as required.

**Component Q (x 2)**

Camshaft setting tools, used to lock the camshaft(s) in their timed position. Designed for single OHC and twin cam, See Fig. 12.



**Fig. 12**

**Component R** - Crankshaft Locking Pin - 1.2/1.4/1.6 engines. See Fig. 13.

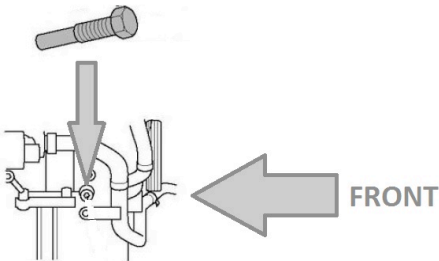

**Fig. 13**

**Component S** - Supercharger support guide pins. Allow the super charger to be slid clear for better access. See Fig.14.

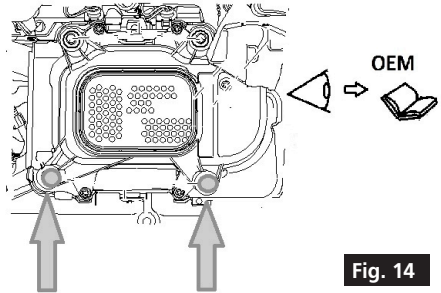

## Safety Precautions

- If the engine has been identified as an Interference engine, damage to the engine will occur if the timing belt has been damaged. A compression check of all the cylinders should be taken before the cylinder head (s) are removed.
  - Do not turn crankshaft or camshaft when the timing belt has been removed
  - To make turning the engine easier, remove the spark plugs
  - Observe all tightening torques
  - Do not turn the engine using the camshaft or any other sprocket
  - Disconnect the battery earth lead (Check Radio code is available)
  - Do not use cleaning fluids on belts, sprockets or rollers
  - Some toothed timing belts are not interchangeable. Check the replacement belt has the correct tooth profile
  - Always mark the belt with the direction of running before removal
  - Do not lever or force the belt onto its sprockets
  - Check the ignition timing after the belt has been replaced.
  - Do not use timing pins to lock the engine when slackening or tightening the crankshaft pulley bolts
  - ALWAYS REFER TO A REPUTABLE MANUFACTURERS WORKSHOP MANUAL
- Warning – Incorrect or out of phase engine timing can result in damage to the valves. It is always recommended to turn the engine slowly, by hand, and to re-check the camshaft and crankshaft timing positions**



[www.kamasatools.com](http://www.kamasatools.com)