



TW X-36 WDK

Tyre fitting machine

twinbusch.de



INSTALLATION, OPERATION AND MAINTENANCE MANUAL



Read this entire manual carefully before installation
or operation of the TW X-36 WDK.
Follow the instructions strictly.

Twin Busch GmbH | Amperestraße 1 | D-64625 Bensheim
Tel.: +49 (0) 6251-70585-0 | Fax: +49 (0) 6251-70585-29 | info@twinbusch.de





Zertifikat

Prüfung der Montiermaschine nach wdk-Prüfleitlinie gemäß wdk-Montage-/Demontageanleitung UHP- und Runflat-Reifen

Hersteller: Twin Busch GmbH
Garage Equipment
Amperestr. 1
64625 Bensheim

Maschinentyp: TW X-36 WDK

Prüf-Nr.: 28-001

Frankfurt/Main, 17. Dezember 2013

Stephan Rau
Technischer Geschäftsführer
Wirtschaftsverband der deutschen
Kautschukindustrie e.V.



IMMLER



TYRE CHANGER INSTRUCTION MANUAL

INDEX	PAGE
1. Introduction:	4
2. Safety Warnings:.....	4
3. Technical data	Fehler! Textmarke nicht definiert.
4. Transport:.....	5
5. Unpacking & Inspection:	5
6. Workplace requirements:	5
7. Position and installation:	6
8. Electricity and Pneumatic connections:.....	6
9. Adjusting operation:	6
9.1 Breaking the tyre bead:	6
9.2 Demounting the tyre:	6
9.3 Mounting the tyre:.....	6
10. Help Arm 056	8
10.1 Technical Data	8
10.2. Safety Regulations	8
10.3. Installation	8
10.3.1. Transport	8
10.3.2. Unpacking	8
10.3.3. Workplace requirement	8
10.3.4. Assembly.....	8
10.4. Parts distribution.....	9
10.5. Trial operation.....	Fehler! Textmarke nicht definiert.
10.5.1. Fixing the tyre.....	Fehler! Textmarke nicht definiert.
10.5.2. Demounting the tyre	Fehler! Textmarke nicht definiert.
10.5.3. Mounting the tyre.....	Fehler! Textmarke nicht definiert.
11. Inflating the tire :.....	11
12. Rapid tyre inflation system :	10
12. 1.Wheel rim lock and tire inflation :	10
12. 2.Inflation for tire with inner tube :	10
12. 3.Inflation for tubeless tire :	10
13. Moving machine:.....	11
14. Maintenance:	11
15. Trouble shooting table:.....	12
16. Exploded drawing:	13
17. Circuit diagram:.....	26
18. Penumatic drawing:	26

Tyre Changer

Warning

This instruction manual is important for the machine, please read carefully before installation and use; also it is important for safe use and machine maintenance of machine. Please keep this manual properly in order to further maintenance of the machine.

1. Introduction:

Application Range: The automatic tyre changer is especially designed for demounting / mounting tyres from wheel rims.

Caution: Please use the machine only for purpose for which it is designed, don't use it for other purposes. Manufacturer shall not be liable for any damage or injury caused by failure to comply with these regulations.

Safety regulation: Use of this machine is especially reserved to trained and qualified professional persons, those who already read the introduction manual carefully, or someone have the experience for operating similar machinery. Any changes and beyond the scope of use on this machine without manufacturer's permission or do not according to the manual, may cause the malfunction and damage to machine, manufacturer can cancel warranty coverage for above. If some parts are damaged due to some reason, please replace them according to the spare parts list. **(Attention: warranty is one year after manufactures' delivery date; warranty excludes the easy-broken parts).**

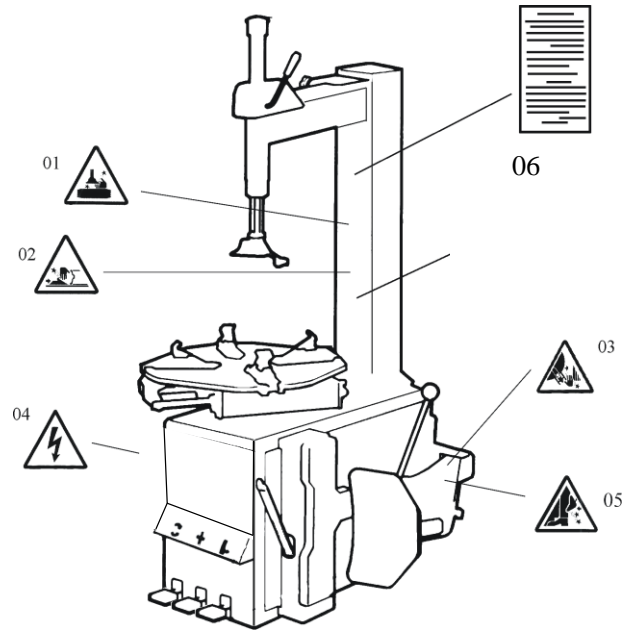

2. Safety Warnings:

- 01 Don't put hands under the Mounting head/demounting head during operation;
- 02 Don't put hands between the jaws during operation;
- 03 Don't put hands in the tyre bead when demounting the tyre;
- 04 Make sure and to check the system is equipped with a good grounding circuit;
- 05 Don't put feet between the Bead Breaker shovel and the body during operation;
- 06 Warning instruction

Security warning labels

Caution:

**When the security warning labels are defaced or off, please recovery them in time!
Do not allow to operate when the security warning labels are missed or imperfect. Do not allow to set any objects to obscure the security warning labels.**

Clients can self-set the warning labels (as right picture show) at any necessary positions.



3. Technical Data

Type	TW X-31	TW X-36 WDK
Rim diameter (outer)	12" - 24"	12" - 24"
Rim diameter (inner)	14" - 26"	14" - 26"
Wheel (max.)	45" (1143 mm)	45" (1143 mm)
Rim diameter (max.)	16" (406 mm)	16" (406 mm)
Pressing weight	2500 kg	3000 kg
Pneumatic connection	8-10 bar	8-10 bar
Power input	380 V	380 V
Motor output	0,75 kW	0,75 kW
Noise level	<70 dB	<70 dB
Net weight (ca.)	246 kg	360 kg

Remark:

Rim dimensions defined at above table are based on the iron wheel rims. Aluminum rims are thicker than the iron wheel rims, so here above rim dimensions are just for the reference.

4. Transport:

When transporting, the machine should be with original package and placed according to the mark on the package. For the already packaged machine should be handled with a corresponding tonnage forklift for loading and unloading. The location to insert the fork feet shown as **Fig 1**

5. Unpacking & Inspection:

Pull out the nail which is nailed on the plate with tip jaw; unpack the carton and plastic cover. Check and make sure all parts shown on the spare parts list are included. If any parts are missing or broken, please do not use the machine and contact the manufacturer or dealer ASAP.

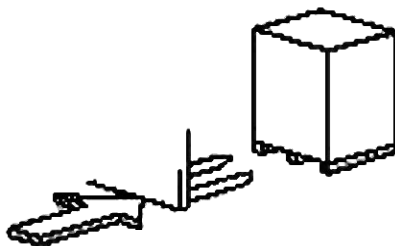

Fig 1

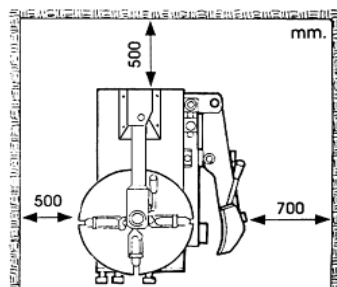

Fig 2

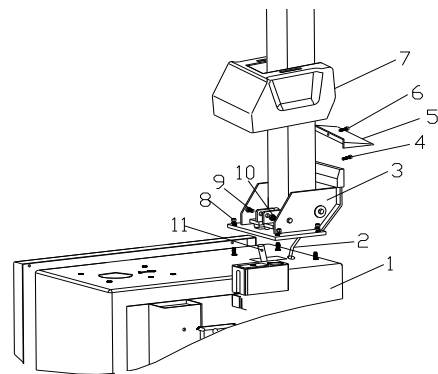

Fig 3

6. Workplace requirements:

Choose workplace in compliance with safety regulations. Connect power supply and air source according to manual and workplace must have good air condition; in order to make the machine run well, its workplace requires at least clear space from each wall shown as **Fig 2**. If installing it outdoor, it must be protected by roof against rain and sunshine.

Warning: the machine with motor must not be operated in explosive atmosphere.

Technical changes for purposes of a technical advancement as well as deviation in colour, errors and printing mistakes are reserved.

7. Position and installation:

Install the column (accessories details refer to the exploded drawing)

- 1) Tools preparation
- 2) Place the tilting seat (3, Fig 3) on the body (1, Fig 3) with 4 bolts (M12), push air hose (2, Fig 3) through the hole of the column. Tighten 4 self-locking nut(8, Fig 3).
- 3) Insert screw (9, Fig 3) into the holes of both column and tilting cylinder shaft (11, Fig 3), tighten it with self-locking nut (10, Fig 3).
- 4) Unscrew the two bolts on the left cover and remove the cover, connect air hose (2, Fig 3) previously mentioned to the side holes which control the tilting 5-way valve. Fix the left cover.
- 5) Fix the plastic cover (7, Fig 3) with two bolts (4, Fig 3).
- 6) Mount the plastic back cover (5, Fig 3) on the column with screw (6, Fig 3).

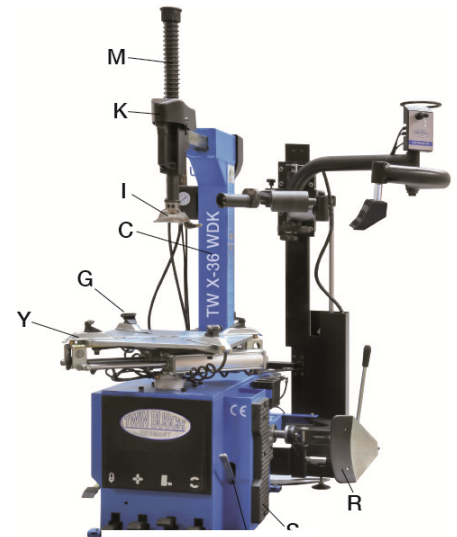

H Fig 4

8. Electricity and Pneumatic connections:

Warning: Before installation and connection, check to be sure that the electricity power supply corresponds to the machine technical data. All the installation of electric and pneumatic devices must be operated by a professional electrician.

Connect the compressed air connector which is on the machine right side with compressed air system. The electric grid that the machine connects to must have fuses protection device and good outer cover grounding protection. Install the leakage automatic air switch on the main power supply, leakage current is set at 30A

Caution: No power plug for this machine, the user should self-connect one power plug no less than 16A as well as in line with the machine voltage. Or directly connect with the power supply according to the above requirements.

9. Adjusting operation:



Tilting pedal (H)



Turntable Rotation pedal (Z)

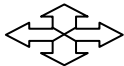

Jaws open and close pedal(V)

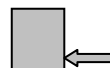

Bead Breaker pedal(U)

Please note: below operation refer to **Fig 4**

Tread the Turntable Rotation Pedal (Z), Turntable (Y) clockwise rotation;

Lift up the Turntable Rotation Pedal (Z), Turntable (Y) counterclockwise rotation.

Tread Bead Breaker Pedal (U), Bead Breaker shovel (R) compress; release Bead Breaker Pedal (U), Bead Breaker shovel (R) back to original position.

Tread totally down Jaws open and close Pedal (V), four clamps (G) on the turntable open; Tread again, four clamps (G) close.

When the pedal is in the middle position, the four clamps stop moving.

Depress pneumatic locking button (K) to lock the Slide arm (N) and Vertical arm (M).

Tread the Bead Breaker pedal (H), the tilting column (C) backwards down; depress again, the tilting column return.

Tyre changer operation is consisted of three parts:

- 1) Breaking the tyre bead
- 2) Demounting the tyre
- 3) Mounting the tyre

Technical changes for purposes of a technical advancement as well as deviation in colour, errors and printing mistakes are reserved.

Caution: Before any operations, don't wear loose clothing and wear protective hat, gloves, and skid-proof shoes. Ensure to exhaust the air in the tyre completely, and remove all the wheel weights from the rim.

9.1. Breaking the tyre bead:

Ensure to exhaust the air in the tyre completely, place the tyre against the rubber buffer (S). Bring the shovel (F) against the bead about 10mm from the edge of the rim shown as **Fig 5**. Depress Bead breaker Pedal (U) to push paddle into tyre. Repeat the above operations on different positions around the tyre and both sides of tyre until tyre bead is released completely.

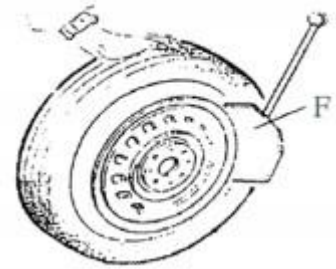

Fig 5

9.2. Demounting the tyre :

Ensure to remove all the weights on the wheel rim and to exhaust the air in the tyre completely before this operation. Apply lubricating grease (or similar lubricant) around the tyre bead. Without the lubricant may lead to badly wear and tear on tyre. Clamp the wheel methods shown as below regarded to the ruled dimension:

a- to clamp the wheel from outside:

Depress the Jaws open and close Pedal (V) halfway down to middle, positioning for the four clamps (G) by reference scale on the Turntable (Y); put the tyre on turntable, hold the rim, and depress the Jaws open and close Pedal (V) until the wheel is secured by the jaws.

b- to clamp the wheel from inside:

Positioning for the four clamps (G) and let them all closed. Put the tyre on the turntable and depress the Jaws open and close Pedal (V) to open the clamps thereby lock the wheel in place.

Caution: Check to make sure the wheel firmly secured by the four clamps before next step.

Lower the Vertical Arm (M) until the Mounting head/demounting head (I) rests next to the edge of the rim, flip pneumatic locking button (K) to lock the Vertical Arm (M) and Horizontal arm in position, and control the distance from Mounting head/demounting head to the edge of wheel rim about 2-3 mm. Insert the Lifting Lever (T) between the tyre bead and the front section of the mounting head/demounting head (I), and move the tyre above the mounting head/demounting head as shown as **Fig 6**.

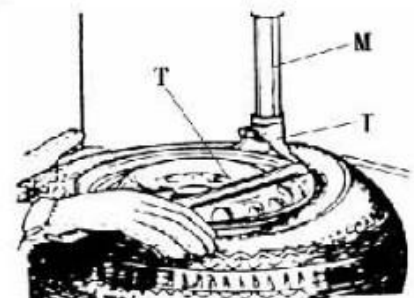

Fig 6

Caution: Chains, bracelets, loose clothes and anything else close to the rotating parts will bring danger to the operator.

With the Lifting Lever held in position, depress the Turntable Rotation Pedal (Z), rotate the Turntable (Y) in a clockwise direction until the tyre is completely separated from the wheel rim.

For the other side tyre demounting, keep using the lifting lever to lift the tyre, make the other side tyre separated from the wheel rim. Depress the Tilting pedal (H), the column backward down, take out the tyre.

9.3. Mounting the tyre :

Caution: Check to make sure that the tyre and the wheel rim are of same size before mounting the tyre.

To avoid any damage on type, lubricate the tyre bead and the wheel rim with the lubrication recommended by manufacturer. Put on the tyre and check the situation.

Caution: When clamp the wheel rim, don't put your hands on the wheel rim to avoid injury during this operation.

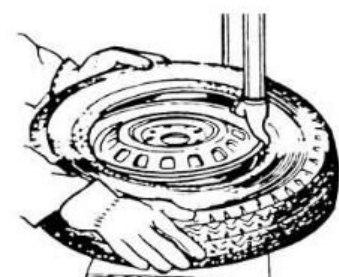

Lock the Hexagonal Vertical Mounting Arm, put the tyre on the rim, let the Rocker Arm back to place as demounting the tyre.

And let one side of tyre down bead above the rear section of the Mounting head/demounting head, the other side under the front section of the Mounting head/demounting head. Suppress the tyre with hands or help arm, and then spin the turntable for mounting the tyre down bead.

Repeat the above operation for mounting the tyre up bead. **(Fig 7)**

10. Help Arm 056

The help arm 056 is an auxiliary device for tire changer, it is used to help to demount and mount tires.

Before any operation of this machine, the operator is requested to read the manual carefully. Do not attempt any operations that are not stated in it. Manufacturer will not be responsible for any injury or damage caused by improper operation. Please keep the manual handy for consulting.

10.1 Technical Data

Work Pressure	8~10 bar
Weight	100kg
Package dimension	1550*310*550mm
Noise Level	LpA<75dB

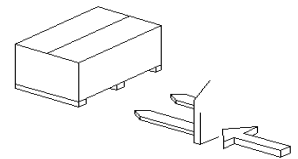

Fig 8

10.2. Safety Regulations

This device is especially reserved to trained professional personnel or somebody who has experiences on mechanical operation and read this manual carefully. This device must be used together with our tire changers, we are not sure it can work with others. Manufacturer won't be responsible for any unauthorized modification

10.3. Installation

Notice!

The installation of this auxiliary device should be done by professional personnel. Before assembly, disconnect the device from power supply and air source.

10.3.1. Transport

Move the device with a forklift truck as illustrated in **Fig 8**.

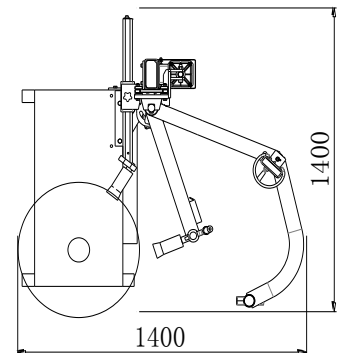

Fig 9

10.3.2. Unpacking

When unpacking, check and make sure all parts shown on the packing list are included. If any parts are missing or broken, please call the manufacturer or the dealer ASAP. Please keep the package out of children's reach.

10.3.3. Workplace Requirement

Fig 9 shows the minimum distance (cm) from walls after assembly this auxiliary device. Please choose the right place to install it.

10.3.4 Assembly

- 1) Disconnect the tire changer from power supply and air source.

Technical changes for purposes of a technical advancement as well as deviation in colour, errors and printing mistakes are reserved.

- 2) Fix the column on the body with four screw1 and adjust the support2 to a suitable location; **(Fig 10)**
- 3) Connect the air hose to the corresponding joint through the rear hole of the body.

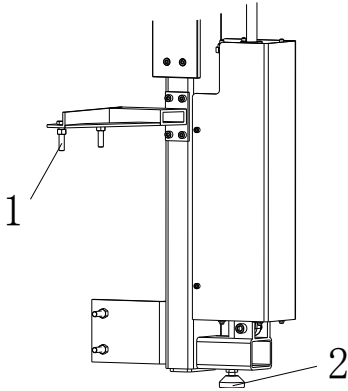

Fig 10

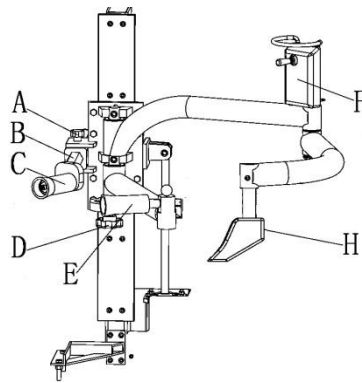

Fig 11

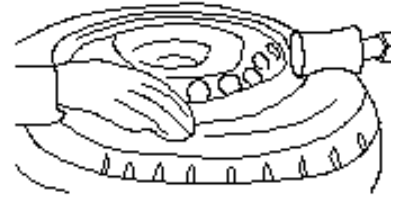

Fig 12

10.4. Functional Parts

Fig 11 shows functional parts to the 056 device:

- | | |
|--------------------------------|-----------------------------|
| A. Little adjustable handle | B. Hexagonal horizontal arm |
| C. Tire lifting roller | D. Large adjustable handle |
| E. Tire lifting roller support | F. Rise/fall switch |
| H. Square tyre pressing head | |

10.5. Operations

Mounting and demounting big flat tire is difficult work. By the help of 056 help arm to mount/demount the tire from the tire bead will make the operation easier. It is a good helper for tire changer.

10.5.1. Fixing The Tire

Loosen the bead according to the manual. Clamp the tire from outside, tread the corresponding pedal to open the jaws; Put the tire on the turntable; Tread the corresponding pedal to close the jaws until they near the rim.

10.5.2. Demounting The Tire

-1. Generally speaking, tire is very tight. Loosen the beads with the tire pressing head first (or using the bead breaker if it too tight to loosen).

Pull out the Hexagonal horizontal arm; let the tire pressing roller above the tire without collision.

Lower the tire pressing roller lower with the switch handle to press the tire. Tread the pedal to rotate the turntable. Loosen the bead during this procedure. **(Fig 12)**

Caution: Lubricate the tire pressing head (upper) and the bead before the operation.

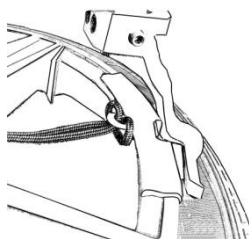

Fig 13

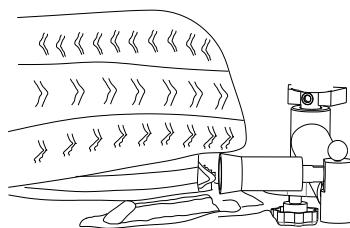

Fig 14

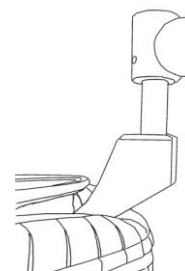

Fig 15

Technical changes for purposes of a technical advancement as well as deviation in colour, errors and printing mistakes are reserved.

-2. Demounting the upper bead

- a- Move the mounting head near the edge of the rim, rotate the tire pressing arm to move the tire pressing block above the tire, press the switch handle to depress the tire, and insert the lifting lever in the clearance between the tire and the rim, then hang the bead on the mounting head.
- b- Raise the auxiliary arm, rotate the tire pressing head to the opposite. Press the tire with the switch handle to create enough space.
- c- Tread the power supply pedal to rotate the turntable. With the help of the tire pressing head, the upper tire bead is detached.
- d- Raise the help arm to move the tire pressing block to its non-working position.

-3. Demounting the bottom bead

Turn the roller support and move it under the tire, but don't touch it with the rim.: (Fig 14)
Tread the power supply pedal to rotate the turntable, meanwhile, lift help arm gradually to loosen tire and completely demount the bottom bead.



图 16

10.5.3. Mounting the tire

Lubricate the tire bead and rotate the turntable, mount the bottom bead with the mounting head;
Pull the hex rod out, press the upper bead under the mounting head 5mm with the tire pressing roller, rotate the rotating arm and move the tire pressing block above the tire;
Don't touch with the rim in the operation, or it causes damage on the rim due to friction.

Tread the power supply pedal to rotate the turntable and the tire pressing block, lower the help arm to press the tire under the rim. Mount the tire with the mounting head. Please pay attention to the safety in the process of operation. (Fig 16)

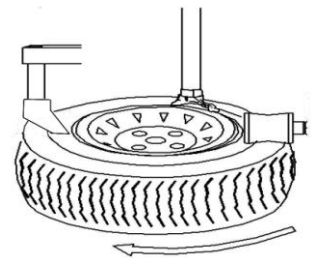
Random accessories and use method:

Steel ring protective sleeve(Fig F1) , V-shape tyre pressing block(Fig F2) , Tyre pressing device of help arm(Fig F3)



Fig F1

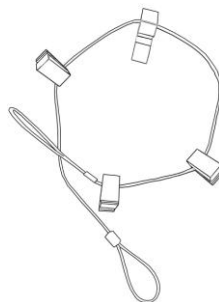

Fig F2

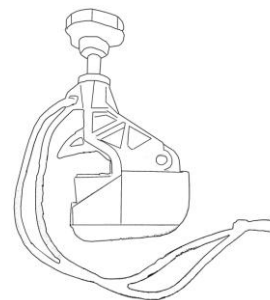

Fig F3

Use method:

1)Steel ring productive sleeve

Fix the steel ring on the edge of the rim(Fig T1),the edge location below the tyre demounting head tyre rim can product the steel ring(Fig T2)

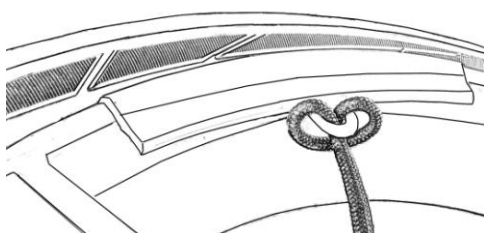

Fig T1

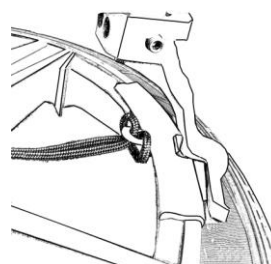

Fig T2

Technical changes for purposes or a technical advancement as well as:

errors and printing mistakes are reserved.

2)V-shape tyre pressing block assembly

During fixing the tyre, inserting the V-shape tyre pressing block into the rim when the rim rotates(**Fig T3**), which can prevent tyres effectively from becoming warping and tighten. To achieve the purpose of good tyre installation (**Fig T4**).

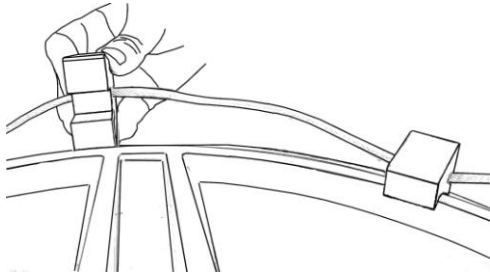

Fig T3

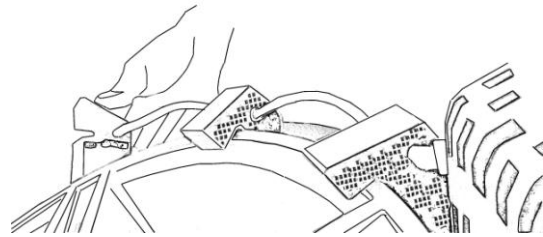

Fig T4

3)Tyre pressing device of help arm

During fixing the tyre, inserting the tyre pressing device of help arm into the rim (**Fig T6**)when the square tyre pressing block press the tyre(**Fig T5**), which can achieve the purpose of stable tyre installation .

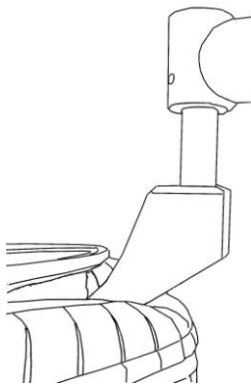

Fig T5

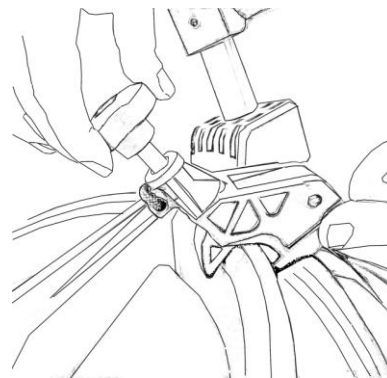

Fig T6

11. Inflating the tire :

Importance: It is very dangerous during inflating operation, take carefully and comply with instruction. When inflating, it will turn to be extremely dangerous if problems happen to tyre or rim. The possible burst force tire goes upward and outward, the big power may cause injury or death of the operator or the people around.

Tyre may burst caused by following:

- 1) The wheel rim and the tyre are not of the same size;
- 2) The tyre or the wheel rim is damaged;
- 3) The pressure of tyre inflation is over the max. pressure recommended by manufacturer;
- 4) The operator fail to comply with the safety regulation;

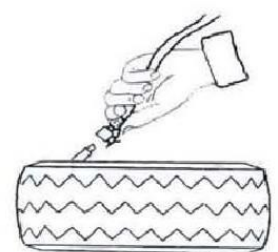

Fig 17

Please operate as follows:

- 1) Remove the valve cap from the valve stem;
- 2) Check to make sure the air nozzle is pressed down completely over the threads of the valve stem.
- 3) Check to make sure that the tyre and the wheel rim are of the same size;

Technical changes for purposes of a technical advancement as well as deviation in colour, errors and printing mistakes are reserved.

- 4) Lubricate both the tyre bead and the wheel rim, additional lubrication is required if needed;
- 5) Inflate the tyre with break, while inflating, check the pressure listed on the pressure gauge, also check whether the bead is fixed or not. Repeat operation above until the bead is secured; you need take special steps when inflating convex rim or double convex rim;
- 6) Continue inflating and check the air pressure frequently until to reach the required pressure. (Fig 17)

Note: Never exceed the max. inflation pressure given by the tyre manufacturer.

Keep hands and your body away from inflating tyres.

Only specially trained persons are allowed to perform the operations, do not allow other to operate or be near the tyre changer.

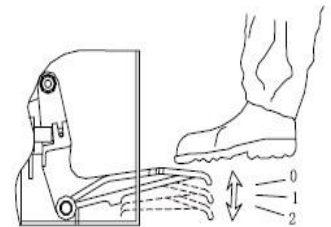

Fig 18

12. Rapid tyre inflation system

1) Rapid Tire Inflation Device:

2) Note: before inflating operation, please make sure the pneumatic power supply connect well.

3) Before operation, must check the devices perform well as follow:

- a. Press Rapid Tire Inflation Pedal to the middle position (Fig 18, position 1), the inflating head should give air.
- b. Press Rapid Tire Inflation Pedal all the way down (Fig 18, position 2), a strong air blast should come from the holes in the four jaws' locking sliders. (Fig 19)

12.1. Wheel rim lock and Tire inflation:

Note: A wheel can explode if:

- 1). the diameter of the rim is not exactly the same at the tyre's.
- 2). the rim or tyre are defective.
- 3). the tyre is inflated to a pressure higher than the maximum recommended by the manufacturer.
- 4). the operator does not observe the requisite safety regulations.

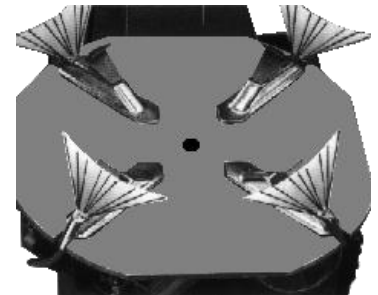

Fig 19

12.2. Inflation for tire with inner tube:

- 1). Remove the valve stem.
- 2). Check to be certain that tyre and rim diameter correspond.
- 3). Check to be certain that rim and beads are sufficiently lubricated.
- 4). Press the pedal down to the middle position to start inflation.
- 5). Release frequently the inflating pedal to check pressure on the manometer. If the air pressure is too high, press the button under the manometer for release the rest air until the correct pressure is reached.

12.3. Inflation for tubeless tire:

Note: When inflating tubeless tire using a strong jet of air, the wheel must be clamped from the inside of the rim.

- 1). Remove the valve stem.
- 2). Check to be certain that tire and rim diameter correspond.
- 3). Check to be certain that rim and beads are sufficiently lubricated.
- 4). Press the pedal down to the middle position to start inflation.
- 5). If the bead of the tyre is not well seated, due to a strong bead, lift tyre manually until the upper bead seals against the rim, then press the pedal all the way down. A strong jet of air will be released through the nozzles in the slides and this will help the bead seal.
- 6). Release the tyre, set the pedal back to the middle position and continue to inflate the tyre to the required pressure. If the air pressure is too high, press the button under the manometer for release the rest air until the correct pressure is reached.

Technical changes for purposes of a technical advancement as well as deviation in colour, errors and printing mistakes are reserved.

Note:

- 1). Failure to follow all warnings and instructions may lead to serious personal injury or death to operator or bystander. NEVER exceed 3.5 bar (50 psi) when seating beads or inflating tyres.
- 2). If a higher tire inflation pressure is required, remove the wheel from the tyre changer and continue the inflation procedure with the wheel inside a special protection cage. NEVER exceed the maximum inflation pressure given by the tyre manufacturer.
- 3). Only specially trained persons are allowed to perform these operations. Do not allow others to operate or be near to the tyre changer.

13. Moving machine:

Please use forklift to move the machine. Disconnect the tyre changer from the electricity power supply and pneumatic power supply, lift the base board and insert the feet of forklift. Then mount the tyre changer machine to a new position and fix it tightly.

Note: the place chosen for fixing the tyre changer must meet the safety regulation.

14. Maintenance:

Caution: only the professional persons can do the maintenance. To prolong the machine's life, maintain the machine timely according to the manual. Otherwise, it will impact the reliability of the machine or even cause injury to operator and others nearby.

Caution: before performing any maintenance, disconnect the tyre changer from the electric power supply and pneumatic power supply, and depress the Jaws open and close Pedal or Turntable Rotation Pedal for 3~4 times to evacuate all compressed air from the machine.

Damaged parts must be replaced by professional persons with the spare parts provided by manufacturer.

- Clean the machine once every day after work. Clean the dirt on the turntable with diesel oil once per week and lubricate the slides and clamps.

- Following maintenance must be done at least once per month:

Check oil level in Oil Fog Maker, please be filled with SAE30# oil if need.

Unscrew with hex wrench (E). Based on connection of compressed air, first to depress Jaws open and close Pedal or Turntable Rotation Pedal 5-6 times, and

then check whether oil in Oil Fog Maker drops down a drip of oil. For continuous operation, depress twice every time, drop down a drip of oil,

otherwise adjust the screw (D) that controlled oil enter with minus screwdriver.

(Fig 20)

Note: After the first 20 days of use, retighten the jaws with tightening screws (B) on the Turntable (Fig 21)

Note: in the event of turntable lose power, check to see if the belt is tight as follow steps:

Remove the left side cover by unscrewing the screws; adjust two screws located on the motor support, keep a suitable distance between motor support and motor base; tight the screws for the belt tension.(Fig 22)

Caution: please disconnect the machine from electric power supply and pneumatic power supply.

Note: If Vertical Arm not be locked or not meet the requirement that 2-3mm from the bottom of Mounting head/demounting head to rim, please adjust Hexagonal Locking Plate, refer to Fig 23 and adjust the (X).

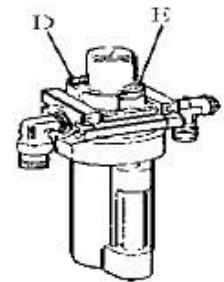

Fig 20

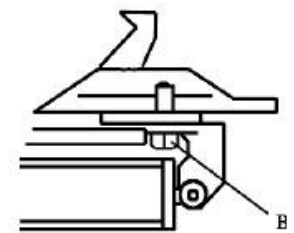

Fig 21

Note: In order to achieve the reliability of jaws and Bead Breaker shovel, operate as follows to keep their valves clean:

1. Remove the left side cover of the machine body by unscrewing the two screws;
2. Loosen the valve mufflers (A) which belong to Jaws open and close Pedal and Bead Breaker Pedal;
3. Clean the mufflers with compressed air, please replace it referring to the spare parts list if it is damaged. **(Fig 24)**

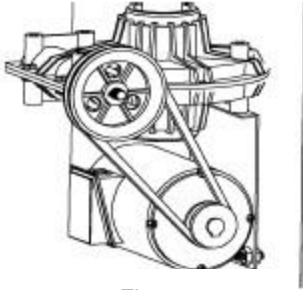

Fig 22

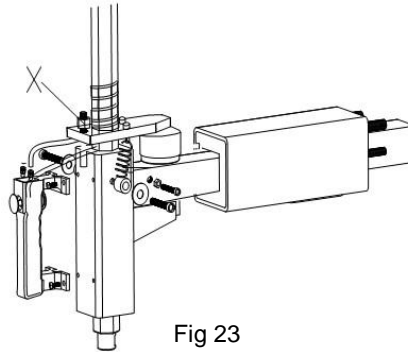

Fig 23

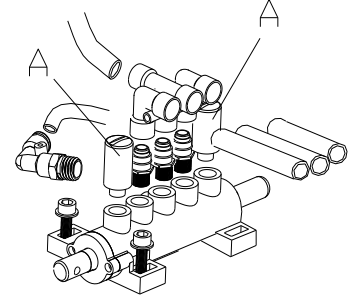
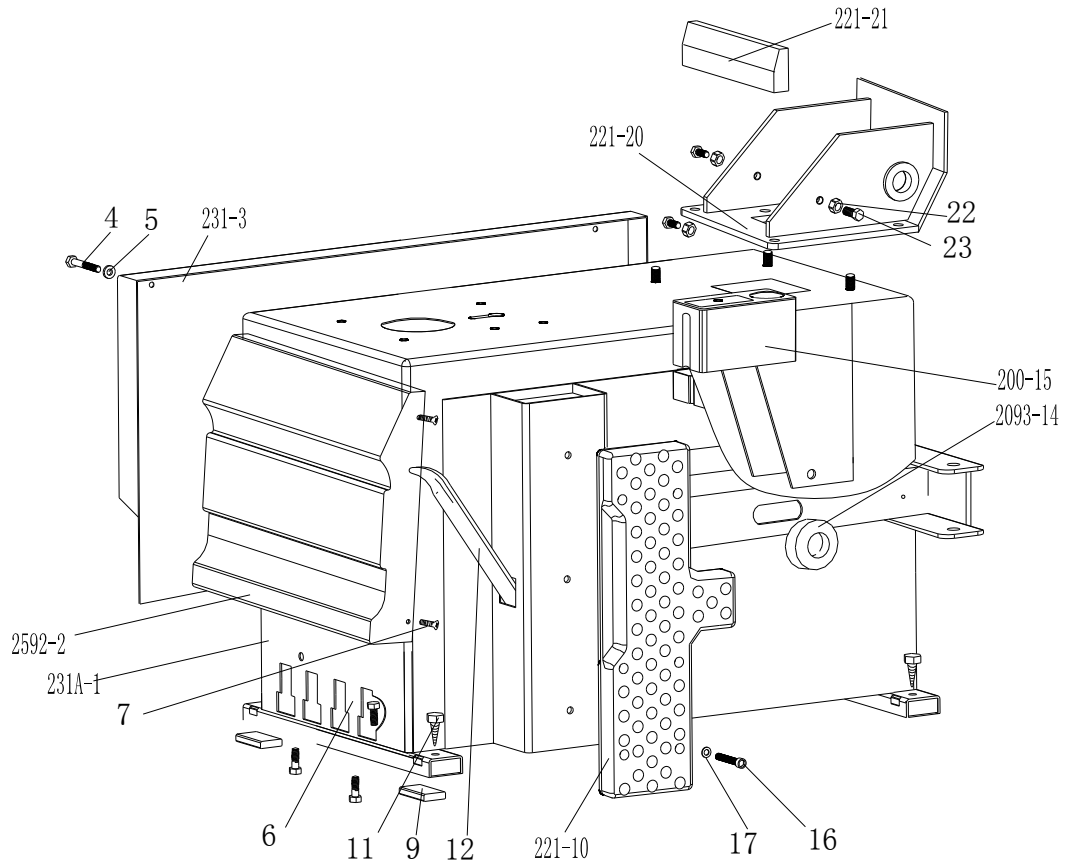

Fig 24

15. Trouble shooting table:

Problem	Reason	Solution
The turntable rotate just in one direction or can't rotate.	Reverse Switch broken	Replace the Reverse Switch
	Belt broken	Replace the belt
	The Motor's malfunction	Check the motor cable or terminal block wire; Replace the motor if it was broken.
Demount or fix the wheel, the turntable can't lock (spin with wheel); The jaws delay to open/close; The turntable locks the rim incorrectly.	Leakage of Air network	Check all the parts on the air network.
	The clamping cylinder can't work.	Replace the cylinder piston.
	Worn jaws	Replace the jaws.
	Broken washers of the chuck cylinder	Replace it.
The mounting head/demounting head always touch the rim during operation.	The locking plate incorrectly adjust or unqualified.	Replace or adjust it.
	Screws on the chuck loose; the Vertical Arm can't be locked by Locking Plate	Tighten the screws; replace the Locking Plate.
The Bead Breaker Pedal and Jaw open and close Pedal can't turn back to the original position.	pedal spring broken	Replace it.
The Bead Breaker shovel operates difficulty.	Jammed silencer	Clean it or replace it.
	The washer on the Bead Breaker cylinder is broken.	Replace it.

16. Exploded drawing:



231A-1	CX-231-010000-0	Machine body
2592-2	CZ-231-080000-0	Pedal front cover
231-3	CX-231-020000-0	Left cover
4	B-010-060101-0	Hex socket head bolt M6x10
5	B-040-061412-1	Flat washer Ø6*14*1.2
6	B-014-080251-0	Outer hex bolt M8x25
7	B-010-060201-0	Hex socket head bolt M6x20
9	C-000-001020-0	Rubber foot buffer
221-10	C-221-500000-0	Bead breaker buffer
11	B-027-060401-0	Grounding screw M6x40
12	C-200-580000-0	Lifting lever
2093-14	C-2093-510000-0	Bead breaker arm rubber
200-15	C-200-470000-0	Oil-water box
16	B-010-080201-0	Hex socket head bolt M8x20
17	B-040-081715-0	Flat washer Ø8*17*1.5
221-20	CX-221-010106-0	Tilting seat
221-21	C-221-820000-0	Tilting protect cover
22	B-001-100001-0	Self-locking nut M10
23	B-014-100251-0	Outer hex bolt M10*25

Technical changes for purposes of a technical advancement as well as deviation in colour, errors and printing mistakes are reserved.

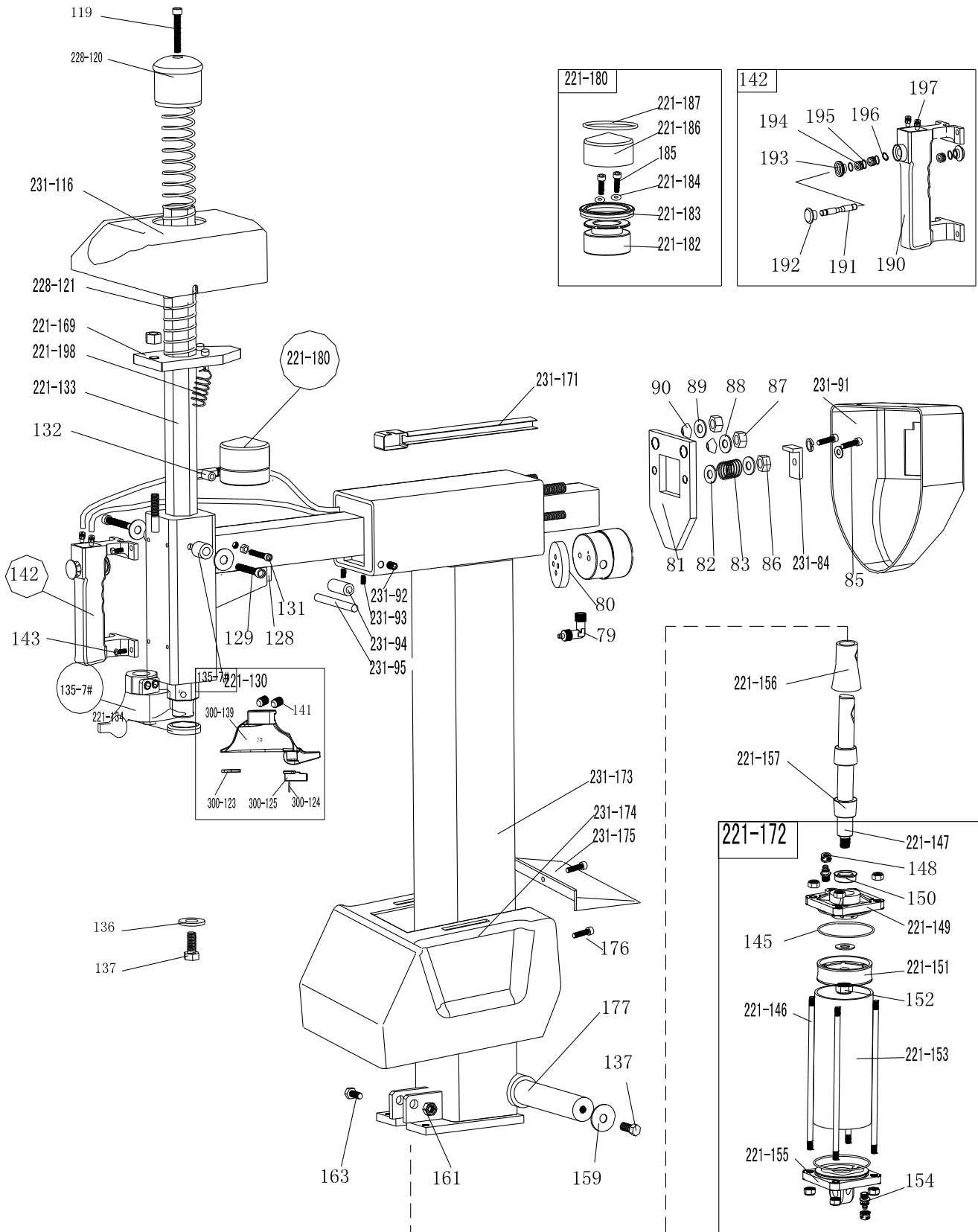

Technical changes for purposes of a technical advancement as well as deviation in colour, errors and printing mistakes are reserved.

79	S-012-010806-0	Quick union 1/8-Ø6	221-146	C-221-350900-0	Tilting cylinder threaded
80	C-221-250600-0	Locking cylinder plate	221-147	C-221-350200-0	Tilting cylinder piston rod
81	CX-231-190000-0	Horizontal arm locking plate	148	B-001-080001-0	Self-locking nut M8
82	B-040-081715-1	Flat washer Ø8*17*1.5	221-149	C-221-350100-0	Tilting cylinder cover without handle
83	C-221-410000-0	Horizontal arm locking spring	150	S-005-020075-0	V seal Ø20*28*7.5
231-84	CX-231-240000-0	Horizontal arm block	221-151	C-221-550000-0	Tilting cylinder piston
85	B-014-080201-0	Outer hex bolt M8*20	152	B-004-120071-0	Nut (silver) M12*1.5*7
86	B-001-080001-0	Self-locking nut M8	221-153	C-221-350500-0	Tilting cylinder barrel
87	B-001-120001-0	Self-locking nut M12	154	S-010-010806-0	Straight union 1/8-Ø6
88	B-040-122520-1	Flat washer Φ 12*25*2	221-155	C-221-350300-0	Tilting cylinder cover with handle
89	B-040-122520-1	Flat washer Φ 12*25*2	221-156	CX-221-351000-0	Tilting cylinder piston rod cover
90	C-221-230000-0	Locking spacer	221-157	C-221-350700-0	Tilting cylinder rubber sheath 1
231-91	C-231-780000-0	Horizontal arm protection back cover	159	B-040-104030-1	Flat washer 10*40*3
231-92	B-007-100161-0	Hex socket head bolt M10*16	161	B-001-120001-0	Self-locking nut M12
231-93	B-007-080161-0	Hex socket head bolt M8*16	163	B-014-120651-0	Outer hex bolt M12x65
231-94	CX-231-251300-0	column side pulley	221-169	CX-221-220000-0	Hex locking board 221
231-95	C-231-251400-0	column side pulley pin	231-171	C-231-790000-0	hose guide
231-116	C-231-480000-0	Horizontal arm protection front cover	221-172	CW-105-021102-0	Complete tilting cylinder
119	B-010-100501-0	Hex socket head bolt M10x50	231-173	CX-231-250000-A	Column
228-120	C-228-490000-0	Vertical arm cap 228	231-175	C-231-460000-0	Tilting Column back cover
228-121	C-228-390000-0	Vertical arm spring	231-174	C-231-450000-0	Column protection cover
128	C-221-200000-0	Shock absorber	176	B-024-050161-1	Cross head screw 5*16
129	B-010-060351-0	Hex socket head bolt M6x35	177	CX-221-260000-0	Column shaft
221-130	P-120-260000-0	guide pulley	221-180		Complete locking cylinder
131	B-010-060161-0	Hex socket head bolt M6x16	221-182	CZ-221-090100-0	Complete locking cylinder piston
132	S-017-010806-2	T-union 1/8-2*O6	221-183	S-005-050065-0	V seal Ø60*50*6.5
221-133	CX-221-160000-0	Vertical arm	221-184	S-000-005200-0	O seal Ø5.6X2
221-134	C-228-520000-0	Vertical arm washer	185	B-010-060551-0	Hex socket head bolt M6x55
135— 7#		Complete mount/demount head 7#	221-186	CX-221-090200-0	Locking cylinder cover Ø60
300-139	C-300-150000-0	Mount/demount head 7#	221-187	S-000-052200-0	O seal Ø52X2
141	B-007-120161-0	Hex socket head bolt M12X16	190	C-221-210100-0	Pneumatic handle switch plate
300-123	C-300-150300-0	Mount/demount head flat protector	191	C-221-210200-0	Pneumatic handle valve rod
300-124	C-200-150400-0	Hex pin	192	C-221-210500-0	Pneumatic valve rod cap
300-125	C-300-150500-0	Mount/demount head protector	193	C-221-210300-0	Pneumatic handle cover
2592-12 5	C-2592-150500-0	Mount/demount head protective washer	194	C-221-210400-0	Pneumatic handle spacer
141	B-007-120121-0	Hex socket head bolt M12X12	195	S-000-007265-0	O seal 7.5*2.65
142	CW-119-021100-0	Complete Pneumatic locking switch	196	B-055-080001-0	Snap ring Ø8
143	B-010-060161-0	Hex socket head bolt M6x16	197	S-010-010806-0	Straight union
145	S-000-068353-0	O seal Ø68.26*3.53	221-198	C-221-400000-0	Hex locking board spring
			199	B-007-100121-0	Hex socket head bolt M10X12

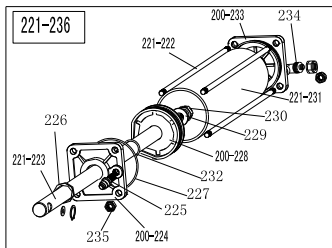
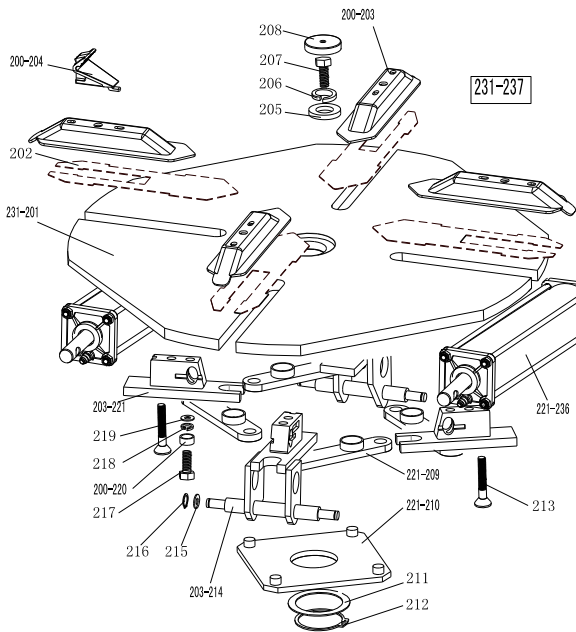

231-201	CX-231-130000-0	Turntable 650
202	CX-221-120300-0	Jaw sliding plate(optional)
200-203	CX-200-120000-0	Jaw cap assembly
204	C-200-570000-0	Jaw
205	CX-200-140000-0	Big washer
206	B-050-160000-0	Spring washer Ø16
207	B-014-160401-0	Outer hex bolt M16x40x1.5
208	C-200-440000-0	Turntable cap
221-209	CX-221-310000-0	Connection rod assembly 615
221-210	CX-221-280000-0	Square turntable 615
211	CX-200-290000-0	Square turntable washer
212	B-055-650001-0	Snap ring Ø65(shaft)
213	B-012-120631-0	Hex socket head bolt
203-214	CX-203-110000-0	Jaw slide guide with pin double holes
215	B-040-122520-1	Flat washer Ø12X25X2
216	B-055-120001-0	Snap ring Ø12(shaft)
217	B-014-120801-0	Hex socket head bolt M12x40
218	B-046-122050-1	Teeth locking washer Ø12x20.5x1
219	B-040-123030-1	Flat washer Ø12X30X3
200-220	CX-200-300000-0	Connection rod nut
203-221	CX-203-110100-0	Jaw slide guide without pin double holes
221-222	C-221-100400-0	Threaded connection rod 393
221-223	C-221-100200-0	Clamping cylinder piston rod 400
200-224	C-200-100100-0	Clamping cylinder cover without handle
225	S-011-010808-0	Straight union 1/8"-Ø8
226	S-005-020075-0	V- seal 20*28*7.5
227	S-000-063265-0	O- seal 63*2.65
200-228	C-200-540000-0	Clamping cylinder piston Ø70
229	B-040-122520-1	Flat washer Ø12X25X2
230	B-004-120071-1	Nut M12X7X1.75
221-231	C-221-100500-0	Clamping cylinder barrel 360
232	S-000-019262-0	O- seal Ø19.6X2.62
200-233	C-200-100300-0	Clamping cylinder cover with handle
234	S-018-010808-0	Union 1/8"-Ø8
235	B-001-080001-0	Self-locking nut M8
221-236	CW-105-021100-0	Complete clamping cylinder
231-237	CW-104-023100-0	Complete turntable 650

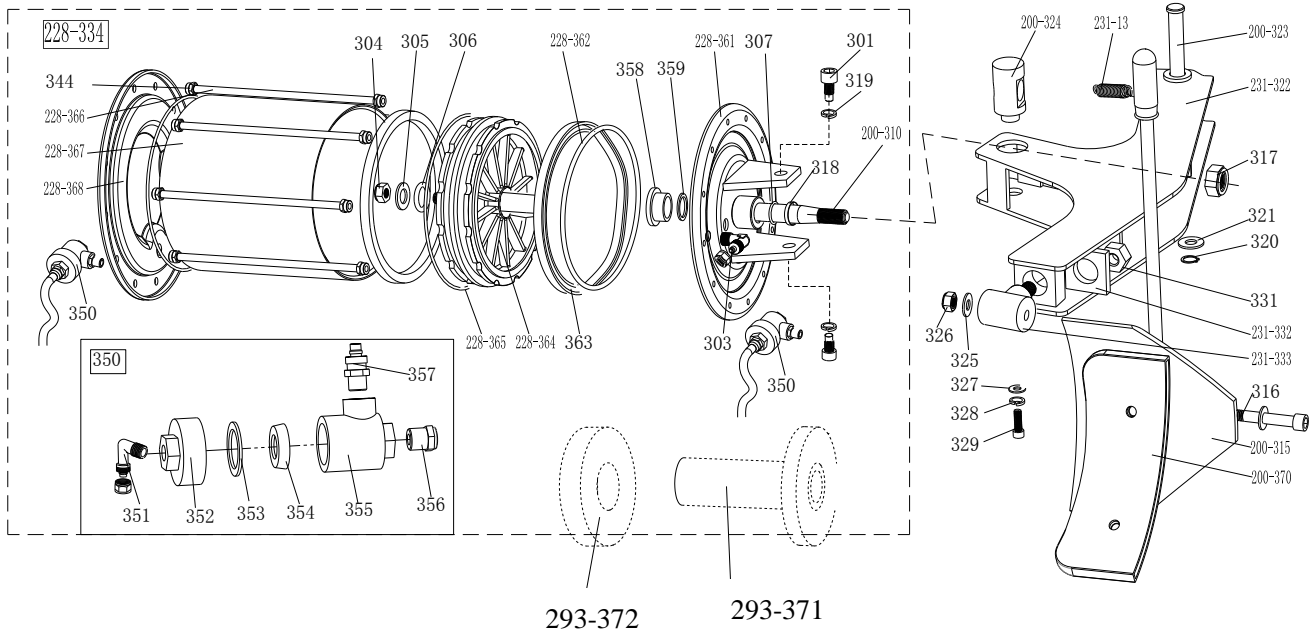

231-13	C-231-360000-0	Bead breaker arm spring	231-333	CX-231-030800-0	Enlarge bead breaker arm rotating shaft
301	B-010-140301-0	Hex socket head bolt M14x30	228-334		Complete bead breaker cylinder D200
303	S-018-010408-0	Union (90°) 1/4-Ø8	344	B-001-080001-0	Self-locking nut
304	B-004-160001-1	Nut M16*1.5	350	CW-112-209800-0	Bead breaker cylinder exhaust valve
305	B-040-162820-1	Flat washer Ø16*28*2	351	S-012-010808-0	Union 1/8-Ø8
306	S-000-016265-0	O-seal Ø 16*2.65	352	C-098-600200-0	Bead breaker cylinder exhaust valve cover
307	S-000-019262-0	O-seal Ø 19.6*2.62	353	C-098-600400-0	Seal washer
200-310	C-200-050100-0	Bead breaker cylinder piston rod	354	C-098-600300-0	Bidirectional seal
200-315	CX-200-070000-0	Bead breaker shovel assembly	355	C-098-600100-0	Bead breaker cylinder exhaust valve barrel
316	B-010-120901-0	Hex socket head bolt M12x90	356	S-023-010401-6	Muffler
317	B-004-160001-1	Self-locking nut M16*1.5	357	S-010-010408-0	Straight union 1/4- Ø8
318	U-006-000001-2	Guide belt	358	CZ-298-050900-0	Nylon sleeve
319	B-050-140000-0	Spring washer Ø14	359	S-005-0200075-0	V-ring Ø20*28*7.5
320	B-055-160001-0	Snap ring Ø16	228-361	CX-298-050500-0	Bead breaker cylinder cover assembly
231-322	CX-231-030000-0	Enlarge bead breaker arm U23110103	228-362	S-000-195265-0	O-seal Ø198*3.1
200-323	CX-200-040000-0	Bead breaker pin	363	S-005-200184-0	Y-seal D200*184*12
200-324	CX-200-050600-0	Bead breaker cylinder pull rod sleeve	228-364	C-298-050200-0	Bead breaker cylinder piston
325	B-040-122520-1	Flat washer Ø12*24*2	228-365	S-000-180500-0	O-seal Ø180*5
326	B-001-120001-0	Self-locking M12	228-366	C-298-051000-0	Threaded connection rod
327	B-040-083030-1	Flat washer Ø8*30*3	228-367	C-298-050300-0	Bead breaker cylinder barrel D200
328	B-050-080000-0	Spring washer Ø8	228-368	C-298-051100-0	Bead breaker cylinder back cover
329	B-014-080201-0	Outer hex bolt M8x20	200-370	C-200-070600-0	Bead breaker shovel protection cover(optional)
331	B-001-160001-0	Self-locking nut M16*1.75	293-371	CX-2093-051000-0	Location screw sleeve

Technical changes for purposes of a technical advancement as well as deviation in colour, errors and printing mistakes are reserved.



231-332	CX-231-030900-0	Enlarge bead breaker arm rotating washer	2293-372	CX-2093-051002-0	Location nut
---------	-----------------	--	----------	------------------	--------------

231-480

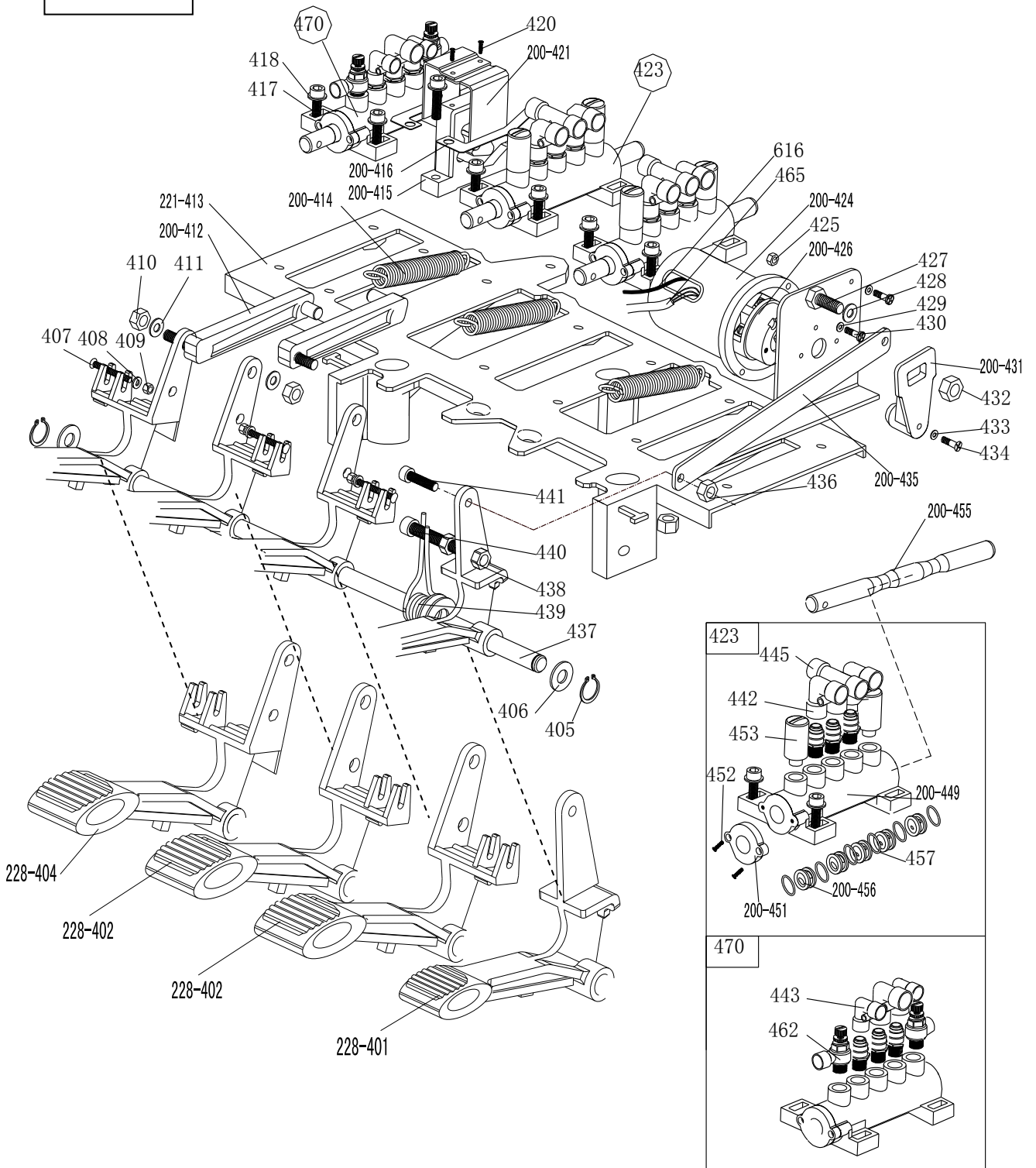

Technical changes for purposes of a technical advancement as well as deviation in colour, errors and printing mistakes are reserved.

228-401	C-228-060400-0	Reverse switch pedal	429	B-040-040000-1	Flat washer Ø 4
228-402	C-228-060300-0	5-way valve pedal(right)	430	B-024-040161-0	Cross head screw M4*16
228-404	C-228-060200-0	5-way valve pedal(left)	200-431	C-200-530000-0	Reverse switch handle
405	B-055-120001-0	Snap ring Ø12	432	B-001-060001-0	Self-locking nut M6
406	B-040-122520-1	Flat washer Ø12*24*2	433	B-040-030000-1	Flat washer Ø3
407	B-024-040301-0	Cross head screw M4X30	434	B-017-030161-0	Cross head screw M3X18
408	B-040-040000-1	Flat washer Ø 4	200-435	CX-200-060600-0	Pedal connection rod
409	B-001-040001-0	Self-locking nut M4	436	B-001-080001-0	Self-locking nut M8
410	B-001-080001-0	Self-locking nut M8	437	CX-200-060700-0	Pedal front shaft
411	B-040-081715-1	Flat washer Ø8*17*1.5	438	B-004-080001-0	Nut M8
200-412	C-200-061300-0	Cam connection rod	439	C-200-370000-0	Pedal twist spring
221-413	C-221-060100-0	Pedal suport board	440	B-010-080501-0	Hex socket head bolt M8x50
200-414	C-200-380000-0	Pedal Spring	441	B-010-080201-0	Hex socket head bolt M8x20
200-415	C-200-061500-0	Cam	442	S-012-010808-0	Quick union1/8- Ø 8
200-416	C-200-810000-0	Cam washer	443	S-012-010806-0	Quick union1/8- Ø 6
417	B-010-060201-0	Hex socket head bolt M6x20	445	S-016-010808-2	Quick T-union1/8-2* Ø 8
418	B-040-061210-1	Flat washer Ø6	200-449	C-200-060901-0	5-way valve barrel (right)
420	B-019-290121-0	Cross head self tapping screw 2.9*12	200-451	C-200-061100-0	5-way valve cover
200-421	CX-200-060500-0	Cam cover	452	B-024-290-121-0	Cross head ST2.9*14
423	CW-110-020001-0	Complete 5-way valve for Bead breaker cylinder	453	S-023-010801-0	Muffler 1/8"
			200-455	CX-200-061200-0	5-way valve rod
200-424	C-200-061400-0	Reverse switch cover	200-456	C-200-061000-0	5-way valve rod spacer
425	B-004-040001-0	Nut M4	457	S-000-012400-0	O seal 12*20*4
200-426	S-060-016000-1	Reverse switch	462	S-030-010806-0	Throttle valve
427	B-010-060201-0	Hex socket head bolt M6x20	470	CW-110-021102-0	Complete tilting 5-way valve
428	B-040-061210-1	Flat washer Ø 6X12X1	465	CZ-000-103150-0	Power supply cable
231-480	CW-109-023100-0	Complete 4-pedals assembly 231	616	CZ-000-205150-0	Motor cable

300A-526

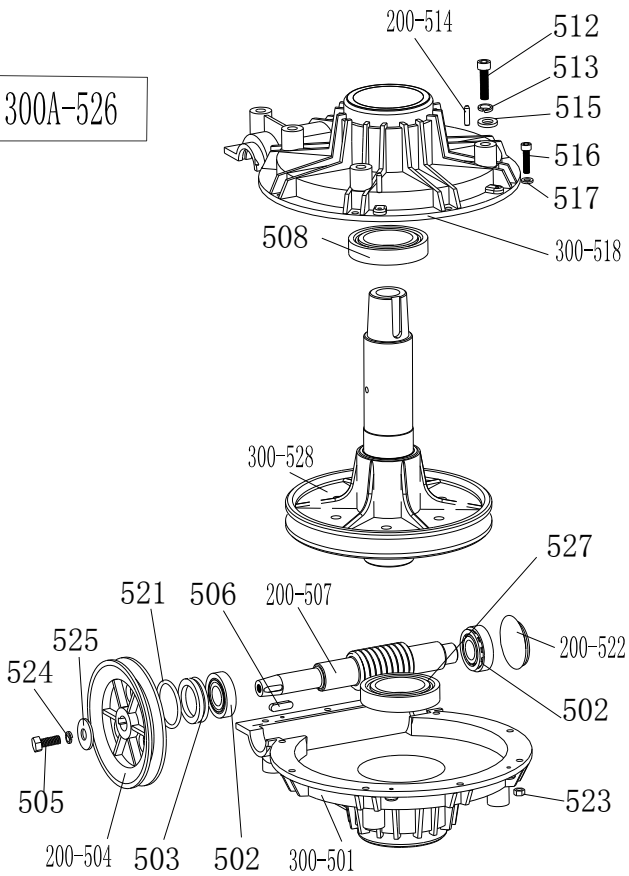

300-501	C-300-320302-0	Gear box lower cover
502	S-040-030204-0	Bearing 30204
503	S-005-020080-1	Gear box seal \varnothing 20*35*8
200-504	C-200-320500-0	Gear Belt pulley
505	B-014-080251-0	Outer hex bolt M8x25
506	B-065-006020-0	Key washer 6x20
200-507	C-200-320400-0	Worm rod
508	S-040-006010-0	Bearing 6010
512	B-014-100551-0	Outer hex bolt M10x55
513	B-050-100000-0	Spring washer \varnothing 10
200-514	B-060-006020-0	Pin 6X20
515	B-040-102020-1	Flat washer \varnothing 10*20*2
516	B-010-060201-0	Hex socket head bolt M6x20
517	B-040-061412-1	Flat washer \varnothing 6*14*1.2
300-518	C-300-320301-0	Gear box upper cover
521	S-000-027310-0	O-seal \varnothing 27.8*3.1
200-522	C-200-320700-0	Oil resistant seal
523	B-001-060001-0	Self-locking nut M6
524	B-050-080000-0	Spring washer \varnothing 8
525	B-040-083030-1	Flat washer \varnothing 8*30*3
300A-526	CW-107-030001-A	Complete gear box
527	S-040-006028-0	Bearing 6208
300A-528	C-300-320100-0	Worm gear

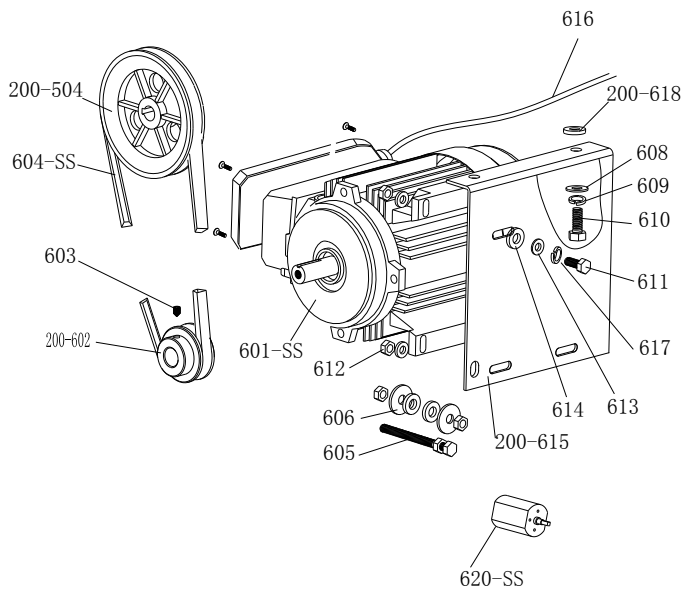

200-504	C-200-320500-0	Gear Belt pulley
601-SS	S-050-400110-8	Two-speed motor 380v
200-602	CX-200-330000-0	Motor Belt pulley
603	B-007-080121-0	Hex socket head bolt M8x12
604-SS	S-042-000660-0	Tyre changer belt 660
605	B-014-080651-0	Outer hex bolt M8X65
606	B-040-083030-1	Flat washer Ø8X30X3
607-80	S-063-008000-0	Capacitor 80µf, 110V
607-50	S-063-005000-0	Capacitor 50µf, 220V
608	B-040-102020-1	Flat washer Ø10X20X2
609	B-050-100000-0	Spring washer Ø10
610	B-014-100251-0	Outer hex bolt M10X25
611	B-014-080351-0	Outer hex bolt M8X35
612	B-004-080001-0	Nut M8
613	B-040-082220-1	Flat washer φ8X22X2
614	C-200-560000-0	Motor rubber washer
200-615	CX-200-340000-1	Motor support
616	CZ-000-205150-0	Motor cable 5x1.0
617	B-050-080000-0	Spring washer φ8
200-618	C-200-560000-0	Motor rubber buffer
620-SS	S-060-030001-0	Speed switch

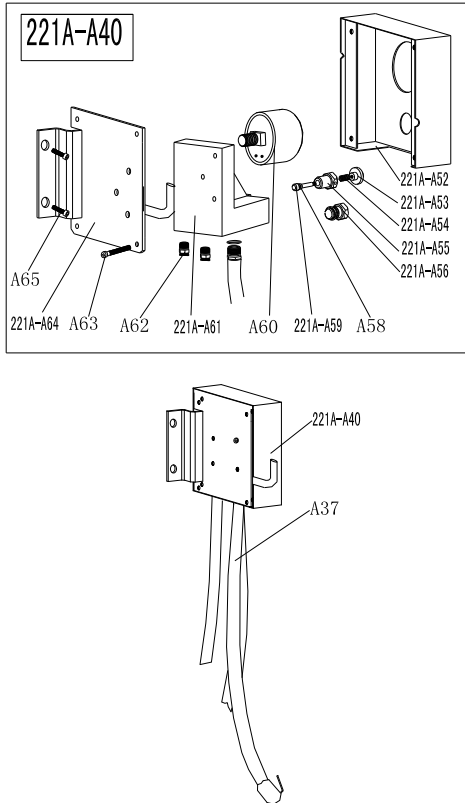

221A-A52	C-221-700000-A	Pressure gauge box Φ 60
221A-A53	C-221-690300-A	Button
221A-A54	C-221-690400-A	Button spring
221A-A55	C-221-690100-A	Button valve
221A-A56	B-007-180081-R	Hex socket head bolt 1/8*8
A58	S-000-004200-0	O-seal 4*2
221A-A59	C-221-690200-A	Button rod
A60	S-038-000020-0	Pressure gauge 10kg
221A-A61	C-221-680000-A	Seat with holes
A62	S-010-010808-0	Quick stright union 1/8- \O 8
A63	B-017-040301-0	cross head screw M4*30
221A-A64	CX-221-710000-A	Pressure gauge box support
A65	B-010-060161-0	Hex socket head bolt M6*16
A37	CX-001-000001-0	Rubber hose 1.5 with clip
221A-A40	CW-118-022100-0	Complete pressure gauge box

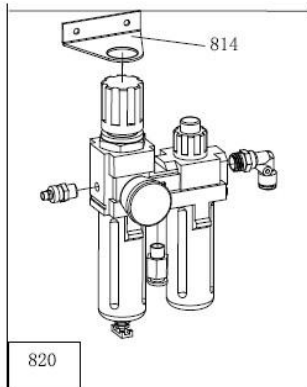

814	C-200-011200-0	Oil fog maker surport
820	CW-114-035000-0	Complete oil fog maker 3500

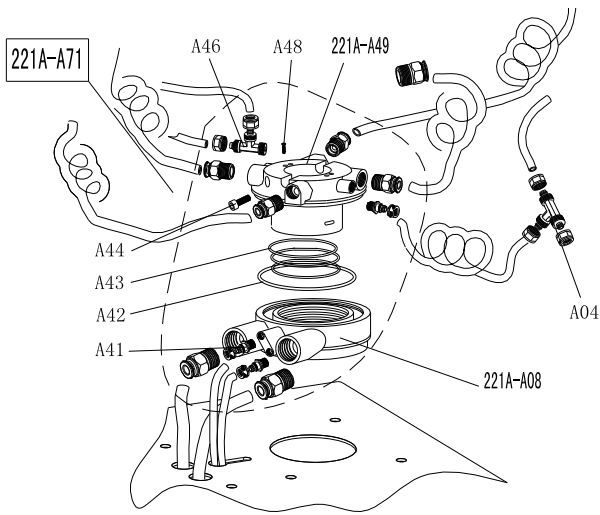

221A-A08	CX-221-430100-A	Rotating valve casing (A)
A04	S-015-000008-3	T-union 3* Ø 8
A41	S-011-010808-0	Straight union 1/8-Ø8
A42	S-000-089200-0	O-seal Ø89*2
A43	S-000-062280-2	O-seal Ø62*2.8
A44	B-010-060201-0	Hex socket head bolt M6X20
A46	S-015-010808-2	T-union 1/8-2*Ø8
A48	B-007-040061-0	Hex socket head bolt M4*6
221A-A49	CX-221-430200-A	Rotating valve mandrel (A)
221A-A71	CW-106-022102-A	Complete Rotating valve (A)

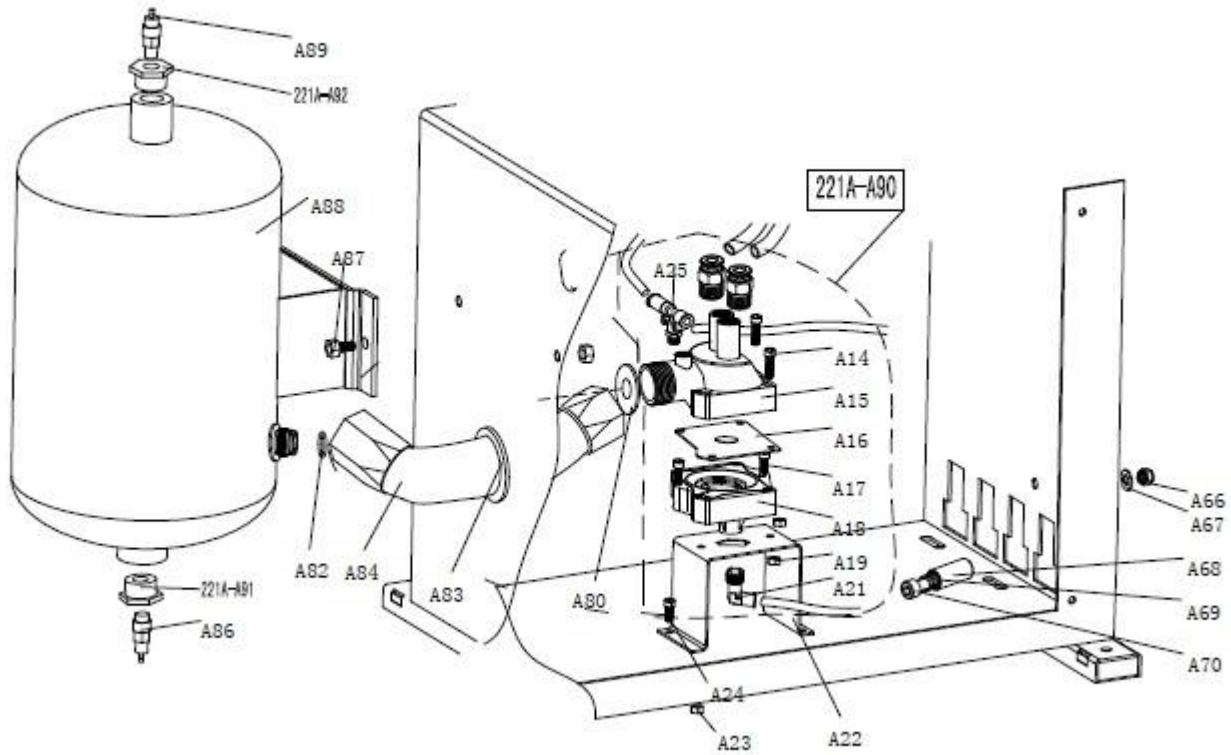

A14	B-010-060301-0	Hex socket head bolt M6*30
A15	C-221-600500-A	Exhaust valve barrel
A16	C-221-600700-A	Exhaust valve rubber washer
A17	B-010-060301-0	Hex socket head bolt M6*30
A18	C-221-600600-A	Exhaust valve cover
A19	B-001-060001-0	Self-locking nut M6
A21	S-012-010408-0	Quick union 1/4-Ø8
A22	CX-221-600800-A	Exhaust valve support
A23	B-001-060001-0	Self-locking nut M6
A24	B-010-060161-0	Hex socket head bolt M6*16
A25	S-030-010450-0	One way valve (EPCVB 8-01)1/8-2*ø8
A66	B-001-100001-0	Self-locking nut M10
A67	B-040-102020-1	Flat washer Ø10*20*2
A68	CX-221-620300-A	Limit spring plate
A69	C-201-670000-A	Limit spring
A70	B-010-100601-0	Hex socket head bolt M10*60
A80	C-221-601000-A	Rubber washer Ø18*34*2
A82	S-000-01625-0	O-seal Ø16*2.65
A83	C-221-720000-A	Hose protector
A84	C-221-601100-A	Metal hose
A86	S-030-010400-0	Water discharge valve
A87	B-014-100251-0	Outer hex bolt M10*25
A88	CX-221-610000-A	Air-tank assembly
A89	S-030-030800-0	Safety valve
221A-A90	CW-112-022101-0	Complete exhaust valve
221A-A91	CX-221-61050-A	Air-tank down union
221A-A92	CX-221-610600-A	Air-tank up union

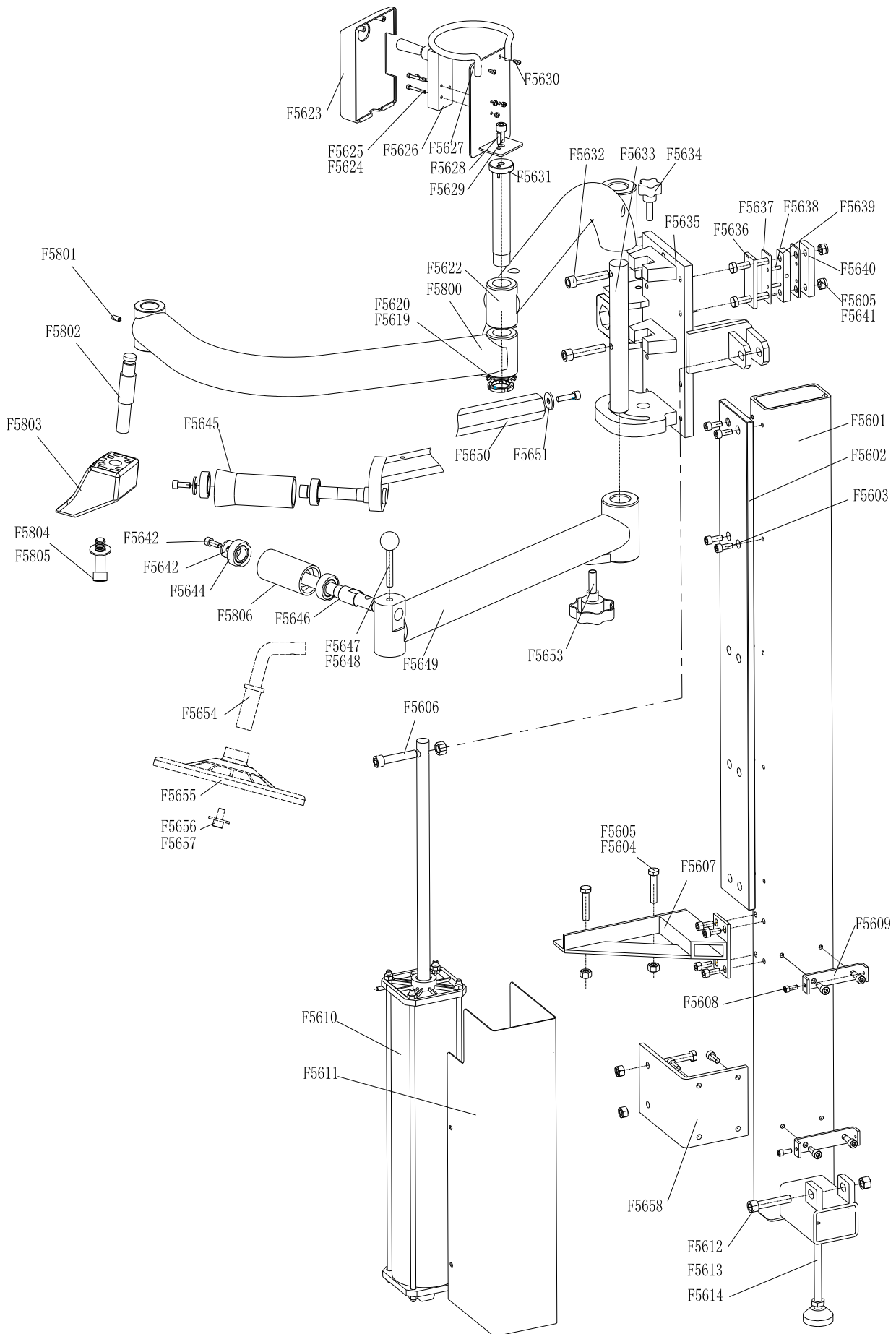

Technical changes for purposes of a technical advancement as well as deviation in colour, errors and printing mistakes are reserved.

F5603	B-010-080251-0	Hex socket head screw M8*25	F5638	CZ-007-080000-0	Counter vane locating pin
F5604	B-001-100001-0	Locking nut M10	F5639	U-006-000001-2	Guidance tape
F5605	B-014-100601-0	Hexagon bolt M10*60	F5640	CX-007-050000-0	Abrasion outer tableting
F5606	B-014-100601-0	Hexagon bolt M10*60	F5641	B-001-100001-0	Locking nut M10
F5607	CX-056-010500-0	Support assembly	F5642	B-010-080201-0	Hex socket head screw M8*20
F5608	B-024-060121-0	Cross round head screw M6*12	F5643	B-040-082220-1	Gasket Ø8*22*2
F5609	CX-056-010700-0	Junction plate of cylinder cover	F5644	S-040-006004-0	Bearing 6004-Z
F5610	C-056-150000-0	Cylinder	F5645	CZ-056-110000-0	Tire pressing cover
F5611	CX-056-100000-0	Cylinder cover	F5646	CX-056-130000-0	Tire pressing spindle
F5612	B-010-121201-0	Hex socket head bolt M12*120	F5647	C-206-120800-0	Bolt handle
F5613	B-001-120001-0	Hex nut M12	F5648	CX-206-120700-0	Bolt
F5614	C-056-170000-0	Supporting leg	F5649	CX-056-050000-0	Tire lifting rod assembly
F5619	B-045-000027-0	Lock washer	F5650	CX-056-040000-0	Tire pressing rod assembly
F5620	B-004-270001-1	Round nut M27	F5651	B-040-083030-1	Big washer 8*30*3
F5622	CX-056-060000-0	Rotating arm assembly1	F5653	C-238-201501-0	Adjustable handle
F5623	C-007-181000-0	Control valve cover	F5654		Tire lifting roller assembly (optional)
F5624	B-017-040301-0	Cross sunk screw M4*30	F5655	C-005-100000-0	Tire lifting roller (optional)
F5625	B-004-040001-0	Nut M4	F5656	B-040-102020-1	Flat washer Ø10 (optional)
F5626	S-030-010818-0	control valve	F5657	B-010-100251-0	Hex socket head screw M10*25 (optional)
F5627	CX-056-120000-0	Control panel assembly	F5658	CZ-056-010600-0	Connecting board
F5628	B-010-050101-0	Hex socket head screw M5*10	F5659	CZ-056-180000-0	Tyre pressing sleeve 2
F5629	B-010-100251-0	Hex socket head screw M10*25	F5800	CX-056-070000-T	Rotating arm assembly 2
F5630	B-024-040161-0	Cross round head screw M4*16	F5801	B-026-100161-0	Screw
F5631	CX-056-080000-0	Connecting pin	F5802	CX-056-140000-T	Rotated shaft of square tyre pressing block shaft
F5632	B-010-120551-0	Hex socket head screw M12*55	F5803	C-056-090100-0	Square tyre pressing block
F5633	C-056-090000-0	Axle	F5804	B-010-100251-0	Hex socket head cap screw M10*525
F5634	C-006-210000-0	Pentagon handle M10	F5805	B-040-101820-0	Flat washer Ø 10*18*2
F5635	CX-056-030000-0	Arm seat assembly	F5806	CZ-056-180000-0	Tyre pressing sleeve 2

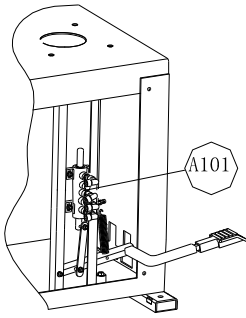

A101

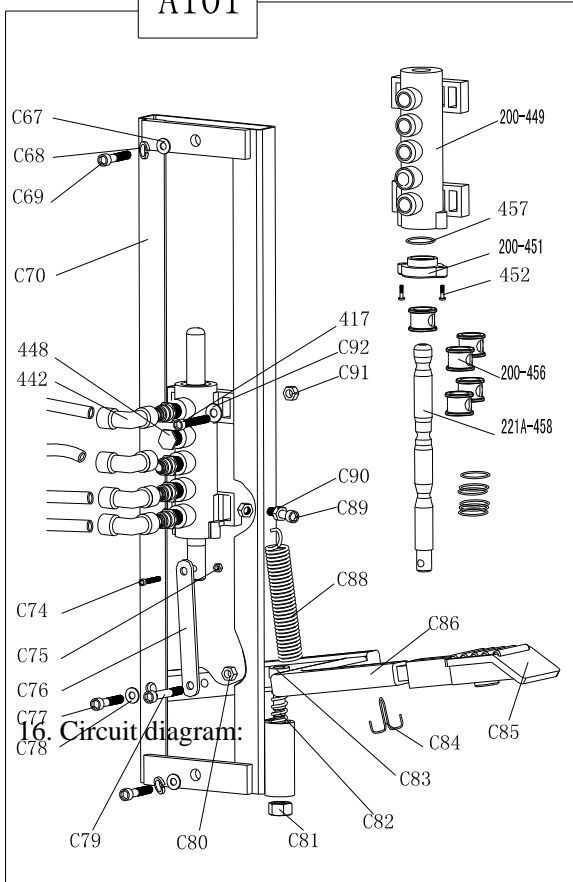

C67	B-040-081715-1	Flat washer Ø8X17X1.2
C68	B-050-080000-0	Spring washer Ø8
C69	B-010-080251-0	Hex socket head bolt M8*25
C70	CX-221-620000-A	5th IT inflating pedal suport assembly
448	B-007-180081-R	Hex socket head bolt 1/8*8
442	S-012-010808-0	Quick union 1/8-Ø8
C74	B-010-050201-0	Hex socket head bolt M5*20
C75	B-001-050001-0	Self-locking nut M5
C76	CX-221-660000-A	Inflating 5-way valve rod
C77	B-010-060251-0	Hex socket head bolt M6*25
C78	B-040-061210-1	Flat washer Ø6*12*1
C79	B-010-060251-0	Hex socket head bolt M6*25
C80	B-004-060001-1	Nut(black) M6
C81	B-001-100001-0	Self-locking nut M10
C82	C-221-670000-A	Limit spring
C83	CX-221-620400-A	Positioning bolt M10X55
C84	B-070-040040-0	Splitpin 4X40
C85	C-221-640000-A	Pedal rubber
C86	CX-221-630000-A	Inflating pedal rod
C88	C-200-380000-0	Pedal Spring
C89	B-010-060251-0	Hex socket head bolt M6*25
C90	B-004-060001-1	Nuta(silver) M6
417	B-010-060201-0	Hex socket head bolt M6x20
C91	B-001-060001-0	Self-locking nut M6
C92	B-040-061210-1	Flat washer Ø6X12X1
200-449	C-200-060901-0	5-way valve barrel
200-451	C-200-061100-0	5-way valve cover
452	B-024-290121-0	cross head screw ST2.9*16
200-456	C-200-061000-0	5-way valve rod spacer
457	S-000-012400-0	O-seal 12X20X4
221A-458	CX-221-650000-A	5-way valve rod A
A101	CW-109-021110-A	Complete inflating pedal

Random accessories

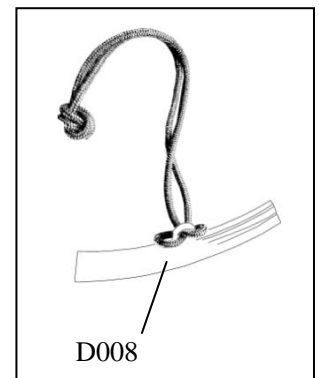
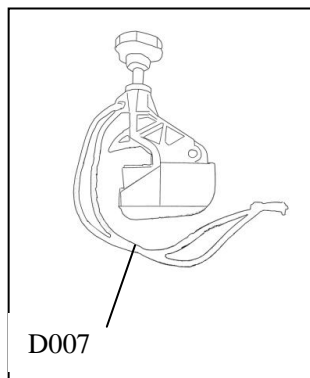
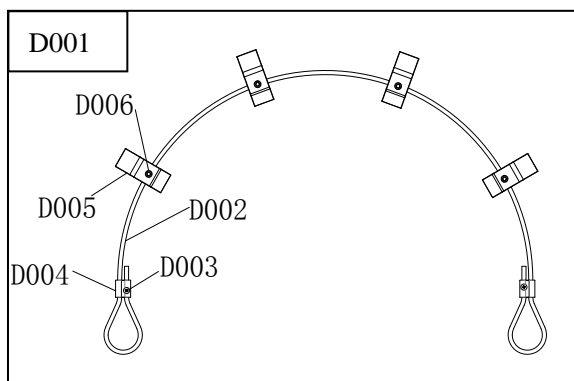

Technical changes for purposes of a technical advancement as well as deviation in colour, errors and printing mistakes are reserved.

D001	CW-155-000002-0	Complete V-shape tyre pressing block assembly	D005	C-056-090301-0	V-shape tyre pressing block U056
D002	C-056-000006-0	Steel rope (with fur)	D006	B-024-050061-0	Cross head cap screw M5*6
D003	B-010-050161-0	Hex socket head cap screw M5*16	D007	CW-155-000004-0	Complete tyre pressing device of help arm
D004	C-056-090302-0	Steel rope lock catch	D008	CW-155-000003-0	Steel RIM protective sleeve

17. Circuit diagram:

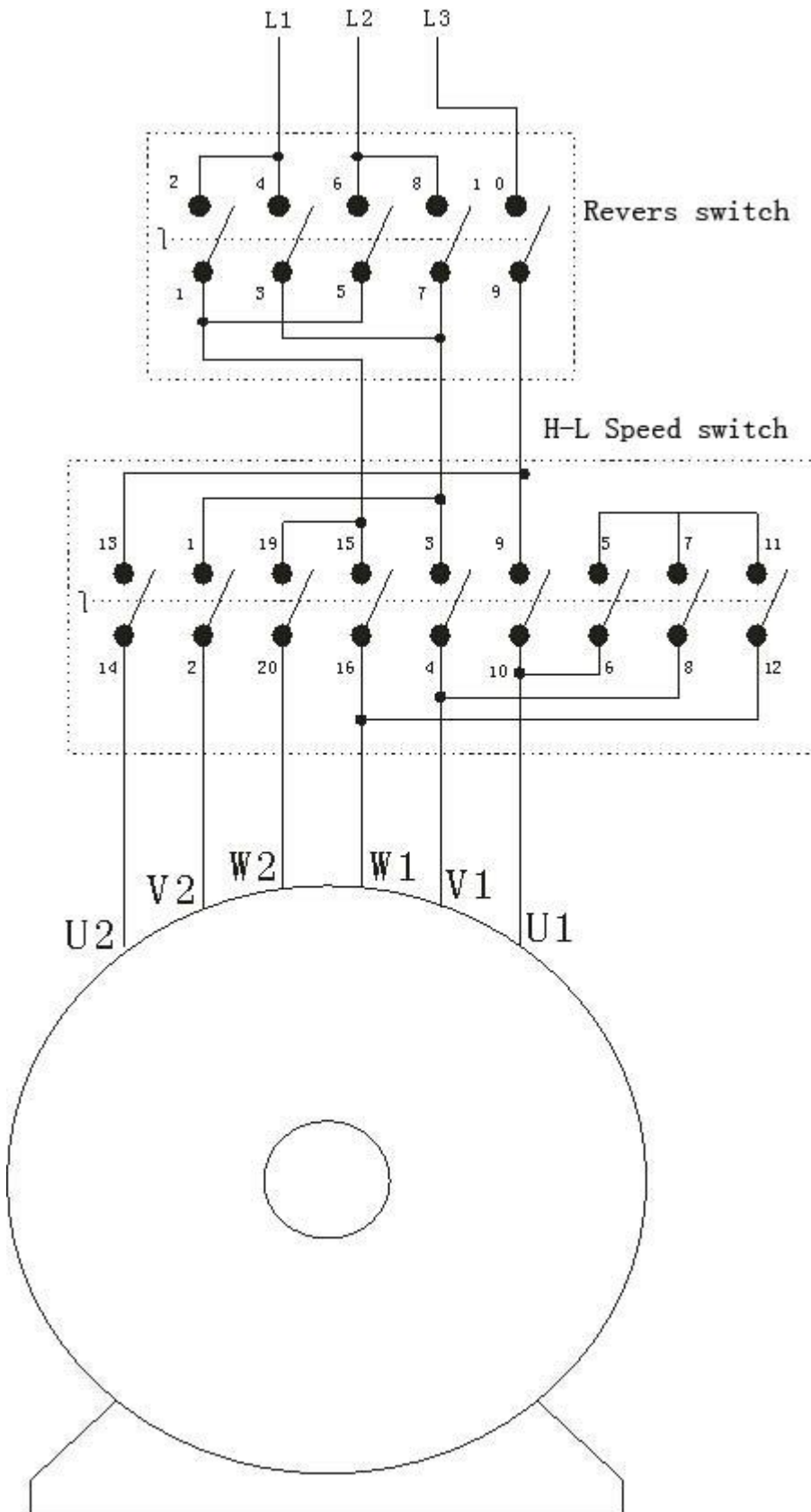

Technical changes for purposes of a technical advancement as well as deviation in colour, errors and printing mistakes are reserved.

18. Pneumatic drawing:

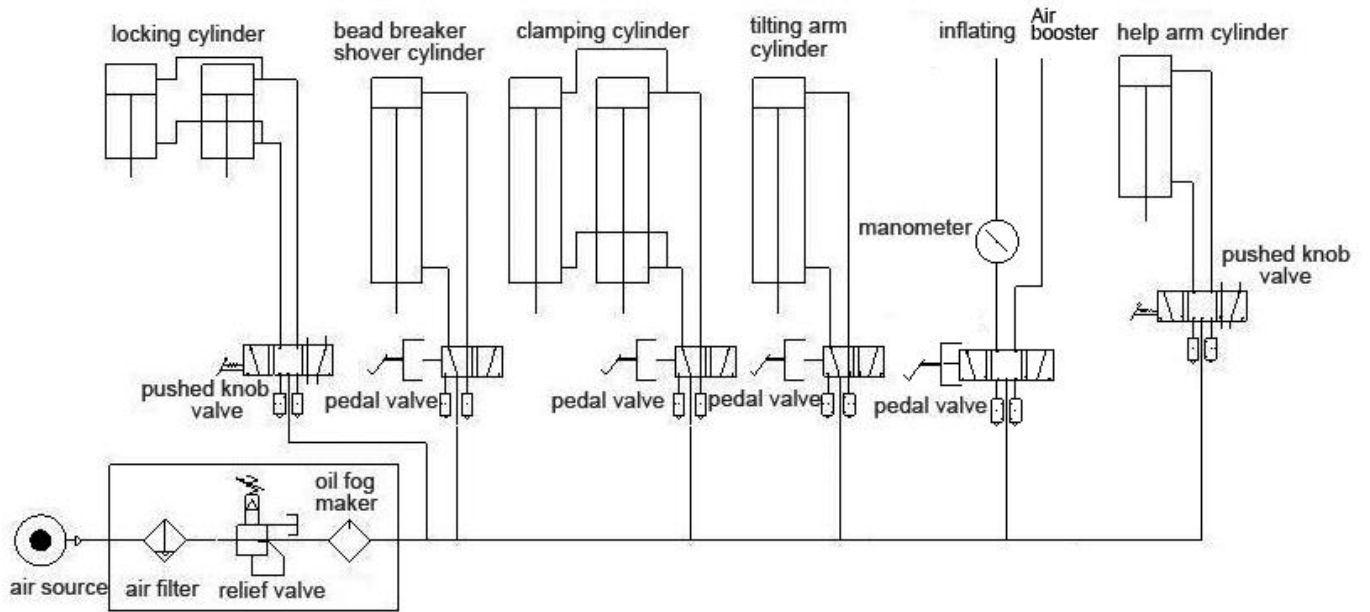



Space for notes:



Space for notes:



Space for notes:



The company

Twin Busch GmbH | Amperestr. 1 | D-64625 Bensheim

declares hereby, that the **vertical tyre changer**

TW X-01, TW X-31, TW X-36, TW X-36 WDK, TW X-39, TW X-98
(TW 1801, TW 1831, TW 1836, TW 1839, TW 1898)

serial no.

in the configuration placed on the market by us, meets the relevant safety and health requirements, as required by the following EC directive(s) in it's/their current version(s).

EG-directive(s)

2006/42/EC machine

Applied harmonized standards and regulations

EN 60204-1/A1:2009 part 1 Safety of machinery - Electrical equipment of machines

CE Certificate

CE-C-0928-11-66-02-2B

date of issue:

09.10.2013

place of issue:

London

technical file no.:

TF-C-0928-11-66-02-2A

Certification body

CCQS UK Ltd.,

Level 7, Westgate House, Westgate Road,

London W5 1YY UK

Notified Body Appointment No. 1105

Any alteration to the equipment, improper use or installation void this declaration.

Authorized person to compile technical documentation is: Michael Glade (adress as below)



TWIN BUSCH GmbH

Amperestr. 1 · 64625 Bensheim
Tel. 08251 / 70585-0 · Fax: 70585-28

Authorized signatory: Michael Glade

Bensheim, 08.12.14 Qualitätsmanagement

Twin Busch GmbH | Amperestr. 1 | D-64625 Bensheim

twinbusch.de | E-Mail: info@twinbusch.de | Tel.: +49 (0)6251-70585-0



Twin Busch GmbH | Amperestraße 1 | D-64625 Bensheim
Tel.: +49 (0) 6251-70585-0 | Fax: +49 (0) 6251-70585-29 | info@twinbusch.de